

## Basic Operation of a Small Gas Turbine

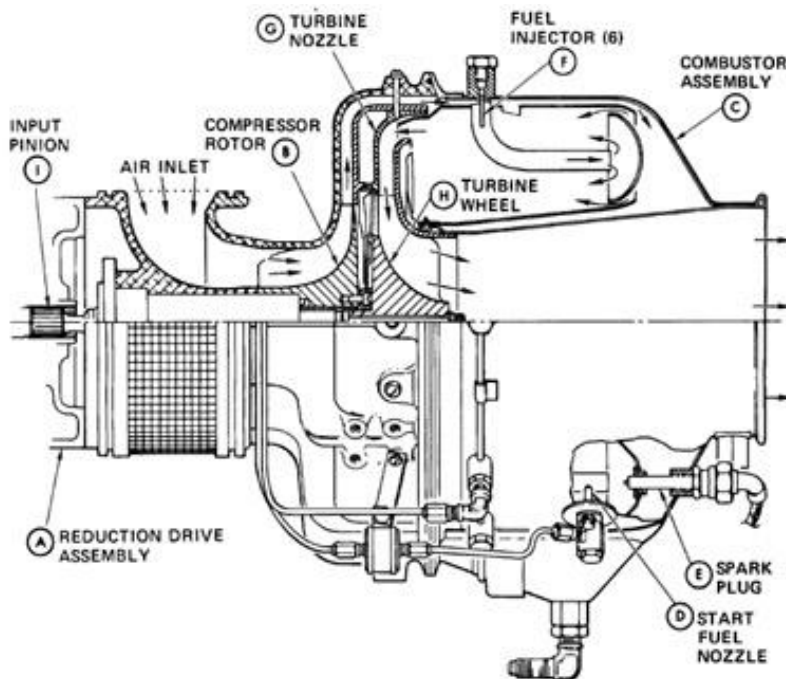

There has been many books written on the subject of gas turbine theory and it would be beyond the scope of this document to go into it in detail here. References will be given at the end of this document for those who need to pursue the theory further. A basic practical description relating to how a small gas turbine engine works follows.

Heat engines all work by utilizing the resulting expansion of a fluid when it has become heated (Normally by the combustion of fuel and air), this fluid is usually found to be air or a gas. If this fluid is compressed before it is heated, then the amount of subsequent expansion will be increased (When the cycle is open to atmosphere). In a piston internal combustion engine, the expansion of gas is restricted as it is placed in the space enclosed by the combustion chamber cylinder and the piston carried by it; This causes the contained pressure to increase and act upon the piston crown thus creating a force upon it. As a result of this force the piston moves and turns a flywheel via a crank. A gas turbine is very similar although the combustion chamber strictly speaking is not enclosed; The expanding heated gas acts upon a turbine wheel that is used to provide power. In a piston engine, the flywheel (Or another piston power stroke) pushes the piston upwards (with energy from a starter or the previous cycle) to compress the ingested air ready for heating and expansion. In a gas turbine, air is compressed using a rotating impeller, which is driven by the turbine.

## [Small Gas Turbines by Ian F Bennett](#)

The pressure in the combustion chamber of a piston engine rapidly increases when the enclosed fuel/air mixture is ignited and heats up. The pressure developed across the piston results in the force placed upon the piston crown. In a gas turbine engine combustion chamber, the combustion process is continuous and takes place at constant pressure. The combustion causes the gases to expand and flow with increased velocity out of it and impinge on the turbine to drive the engine and an external load.

A very important application of a gas turbine was first suggested by the engineer and pilot Sir Frank Whittle. Whittle did not invent (although he did contribute enormous advances to it) the gas turbine or even jet propulsion but put forward the visionary concept of putting the two principals together to create the turbo-jet engine (At that time many others believed the gas turbine could best be used to drive a propeller or air screw). A running gas turbine is a prime mover that naturally produces a high mass flow of heated gas (consisting of a mixture of air and combustion products). The exhaust from a gas turbine engine may be directed through a restricting nozzle to propel the engine forward. A combination of the momentum increase of the mass of air flowing through the engine and the pressure developed across the exhaust nozzle creates a reaction upon the engine; this reaction produces what is known as thrust. This is how a turbo-jet engine operates; the "load" on the gas turbine is created by the exhaust nozzle, the engine "pumps" it's own exhaust gases through it. All turbo-jet engines are gas turbines, but not all gas turbines are used in this way and can be considered to be turbo-jet engines.

The principal difference between a piston engine and a gas turbine is that the processes in a gas turbine are simultaneous and continuous; in a piston engine these processes occur individually as a number of repeating cycles. If you study the temperatures and pressures within heat engines, more detail differences between turbines and pistons become apparent. Aerodynamics also play a key role in gas turbine operation, the flow of gases through passages, around turbine blades and inside compressors is crucial to their efficient operation. Throughout a gas turbine engine there are many passage-ways, ducts and nozzles through which the working gases pass, the cross-sectional areas and profiles of these components form much of the overall design.

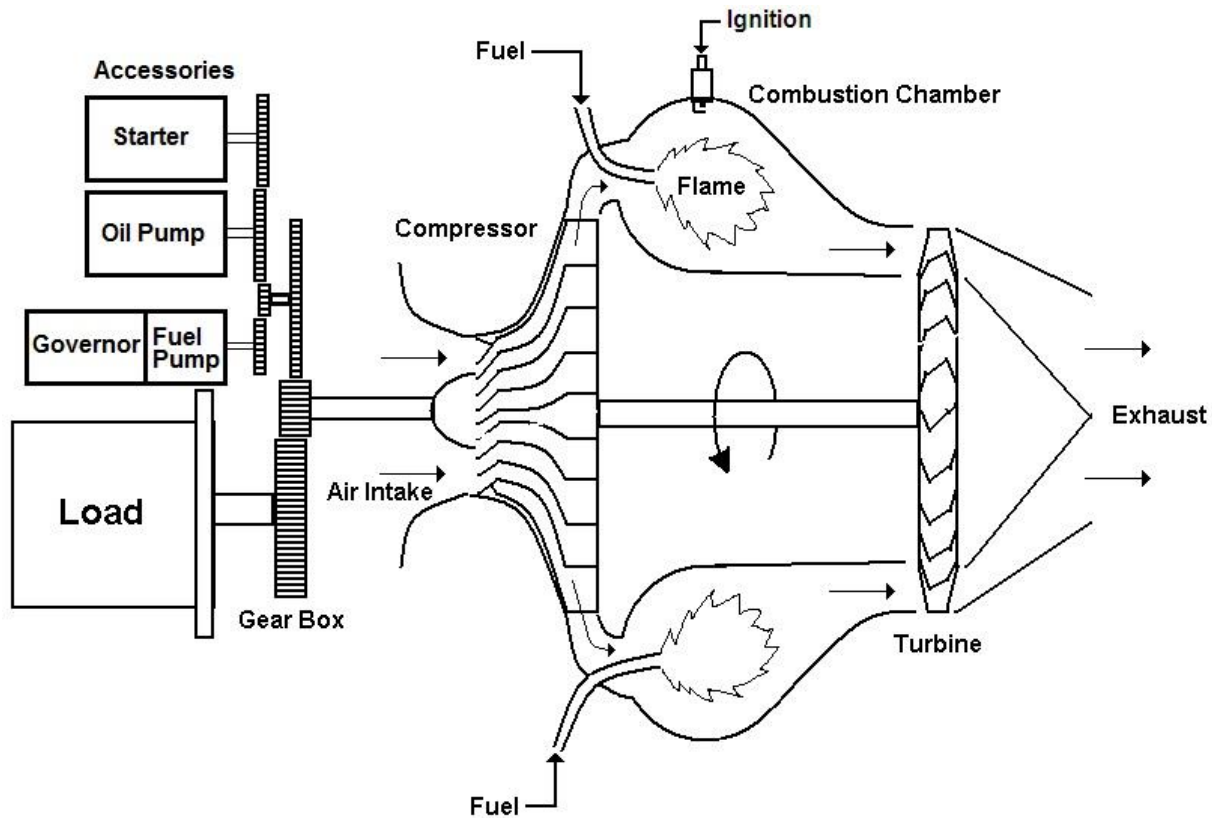

### The working diagram of a simple gas turbine engine

All gas turbine engines consist of a number of fundamental component parts, broadly speaking, these component parts can be likened to the operating cycles of a piston engine. The main component parts in a gas turbine engine consist of a compressor, a combustion system, (sometimes known as a combustor or combustion chamber), and one or more turbines, in addition, the areas through which the air enters the engine and the exhaust gases leave the engine are also important. The compressor and turbine are always connected with a common rotating shaft that is supported by bearings to allow it to rotate at high speed. Typical rotational speeds vary from 10,000 rpm in a large turbo-jet engine through 60,000 rpm in a 100HP APU to over 125,000 rpm in a small model aircraft size engine. The components of the engine from the compressor onwards i.e. the combustion chamber, turbine nozzle, turbine and exhaust are sometimes referred to as the "Hot Section" components of the engine.

The working cycle of a gas turbine is initiated by the starter, often an electric motor. The shaft is rotated by the starter and the compressor wheel draws in air inducing a flow through it. The air is compressed by the action of the wheel itself and a surrounding stationary component known as the diffuser. In a basic engine design the air from the

## [Small Gas Turbines by Ian F Bennett](#)

compressor is passed to a combustion system. The combustion system is formed by a chamber that mixes the air with fuel that is burned. The fuel air mixture is initially during starting ignited by an electrical spark igniter, once lit it burns continuously until the engine is shut down. The resulting combustion introduces heat into the working cycle creating gases that expand as they get hot and exit the combustion chamber with added energy. The hot gases are directed through another stationary component a nozzle that directs streams of hot gases that impinge on the turbine spinning it around. As the compressor and turbine rotate, they accelerate under the combined action of the starter and the hot gas stream, as speed increases the compressor discharge pressure also increases overcoming losses and a point is reached where the cycle is self-sustaining and no longer requires the assistance of the starter. The process continues and the rotor eventually reaches a governed speed controlled by heat input and hence the fuel flow. A load may then be applied to the engine and useful power extracted.

The gas turbine in its simplest concept may be likened to a windmill or turbine connected to a fan or propeller. If this arrangement is rotated, wind from the fan would impinge on the turbine and drive the whole thing around. This would be perpetual motion and of course does not work! If heat is added (a source of external energy) between the fan and the windmill then the air expands and hits the windmill with increased ferocity creating a force that could assist in driving it around. In practice this still does not work as the losses (air escapes and leaks around components) are very high and the net forces at atmospheric pressure are very low. The individual component efficiencies could be improved by enclosing them in a housing, making the fan into an impellor shaped wheel, sculpturing the turbine and tailoring the gas flow into it. If this arrangement is spun around by an external driving force (starter), and if it is spun fast enough with sufficient heat added (but not too much as to melt the hot components), then the process will become self supporting and the device runs on its own. This is the gas turbine principal, a device has been created that drives itself and expels hot gases in its exhaust. If a restricting nozzle is place in the exhaust, the gas velocity may be increased, a combination of the pressure drop across the nozzle exit diameter and the accelerated mass flow of gas though it creates a reaction on the whole engine assembly and it is known as thrust. The gas turbine has become a simple jet engine.

[Small Gas Turbines by Ian F Bennett](#)

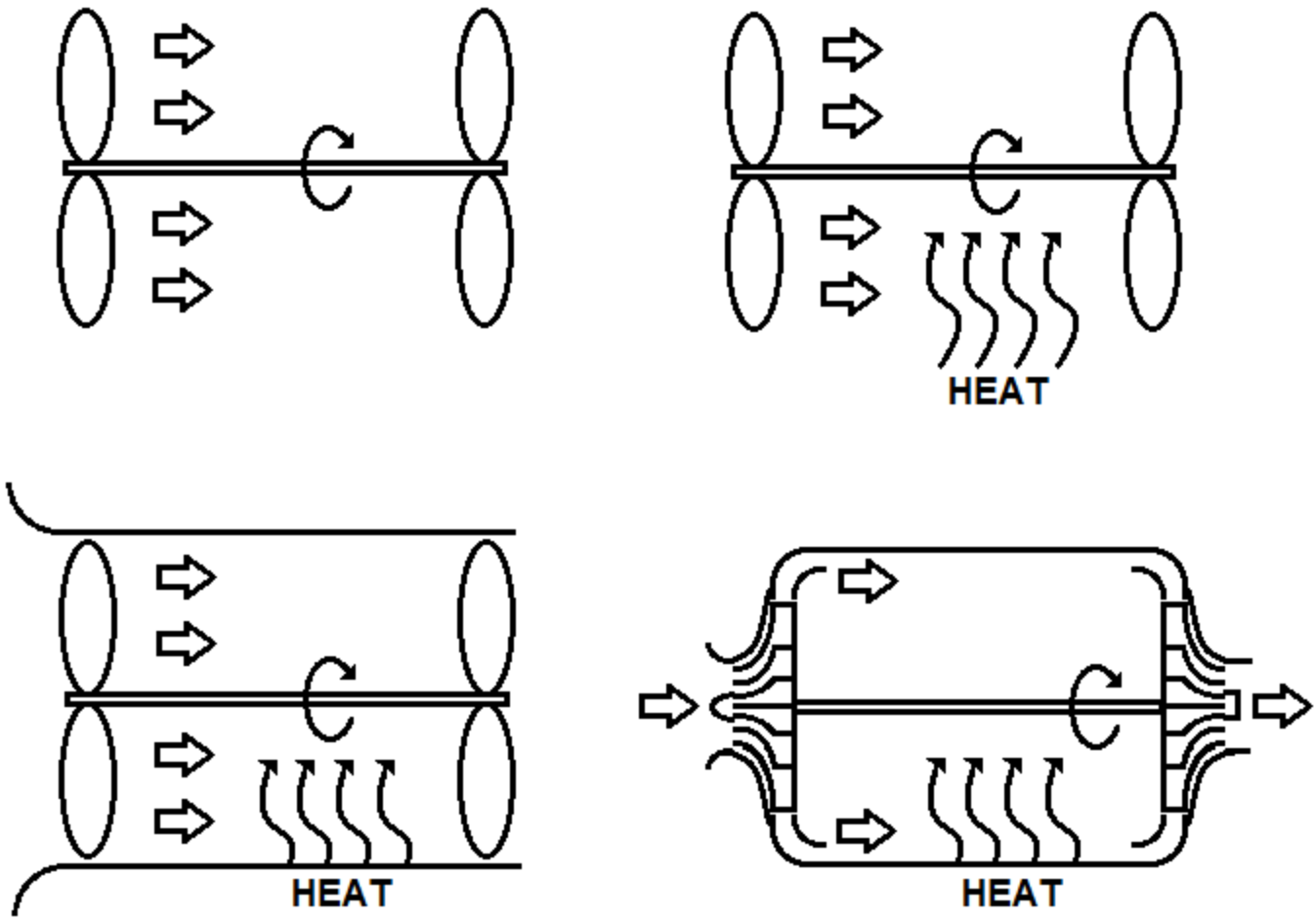

Steps towards the realization of a working gas turbine

[Small Gas Turbines by Ian F Bennett](#)

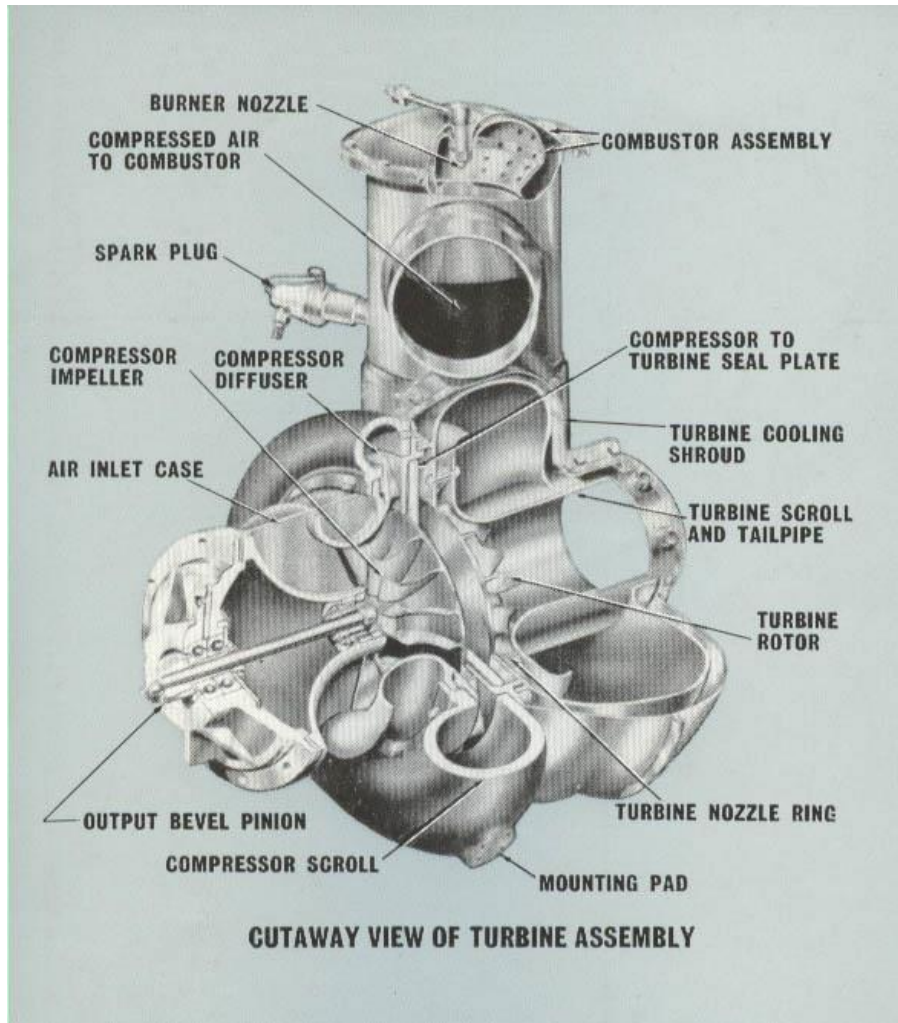

**Cutaway view of a simple small gas turbine engine with can combustor and radial turbine (Perkins Mars)**

## [Small Gas Turbines by Ian F Bennett](#)

### **Air intakes**

The air intake(s) on a small gas turbine engine may be found at the front or to the side of the unit (the front in most cases is at the opposite end from where the exhaust gases emerge). Air is guided into the engine by a simple bell-mouth shape or by one or two converging ducts. Certain designs incorporate a partial enclosure built around the air intake, this forms a plenum chamber or air box. A gearbox is often used to drive a mechanical load and various engine accessories, this is normally placed at the front of the engine (in the case of a single shaft engine) and the air is drawn in around it. The rear or exhaust end of a gas turbine is generally hotter than the front, so all the temperature sensitive devices are to be grouped towards the front. Certain designs use the intake air to help cool the lubricating oil via an oil cooler radiator. Air intake filters are relatively rare but certain models of ground based stationary engines come equipped with large industrial type filter screens.

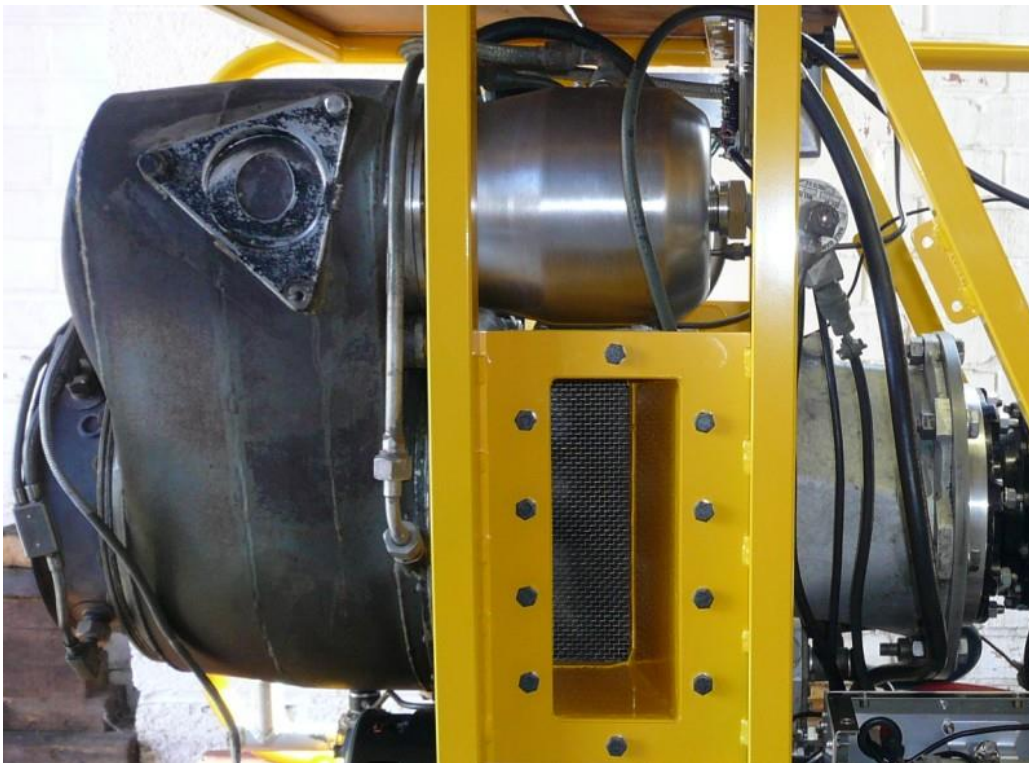

**Gas turbine engine featuring side air intake (Rover 1S60)**

A considerable amount of noise emerges from the air intake whilst a gas turbine operates; it is possible to fit devices such as silencers and baffles to help reduce this noise. Gas turbine silencers are often bulky and are generally only found fitted to ground based stationary engines, compressors and generator sets where sufficient room is available to construct an acoustic enclosure around them.

For their physical size and horsepower, gas turbine engines draw relatively large amounts of air (compared to a piston engine of similar horsepower) into the compressor.

## [Small Gas Turbines by Ian F Bennett](#)

Considerable suction is present in the air intake that will create a hazard. There is also a small pressure drop in the region of the compressor intake resulting from the converging restriction and the acceleration of the air as it is induced into the compressor. The addition of intake screens, enclosures or silencing devices may increase this pressure drop through them and could adversely affect the operation of the engine. Attention should be paid to their specification and design to prevent any significant loss of performance. In the case of propulsion engines there is arguably a very small additional thrust placed upon the engine due to the intake area static pressure being below that of atmospheric.



## Particle Separators

With curtain installations it may be necessary to fit a device known as a particle separator to the gas turbine air inlet system. Particle separators consist of many small cells approximately 30mm in diameter containing a vortex inducing arrangement. A small screw helix type baffle mounted in a tube rotates the incoming air stream creating a vortex. Heavy particles become "centrifuged" out to the outside diameter of the tube. Air exits the tube from the centre via a snout arrangement, the unwanted heavier-than-air particles pass out of the tube around the snout. Many individual tube separators are placed in a box arrangement and the unwanted particles collect in the box and may be extracted with a small blower unit or venturi excited with a compressed air nozzle.

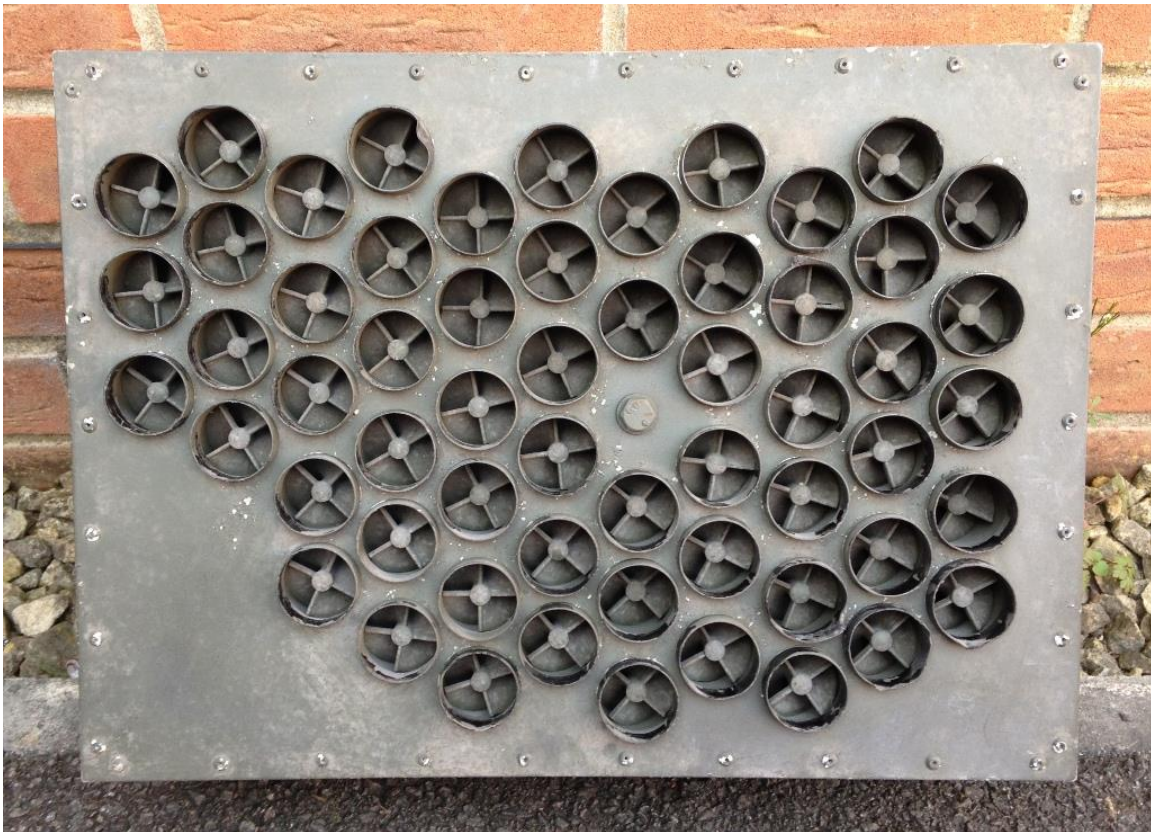

### **A Particle Separator for fitment to a small gas turbine engine**

The particle separator unit must be reasonably matched to the engine mass air flow, too smaller a unit will result in excessive pressure losses and air intake drop reducing engine performance. Too large a unit will result in poor filtration as the individual air flows in the cells will not induce vortices of sufficient magnitude to separate the particles.

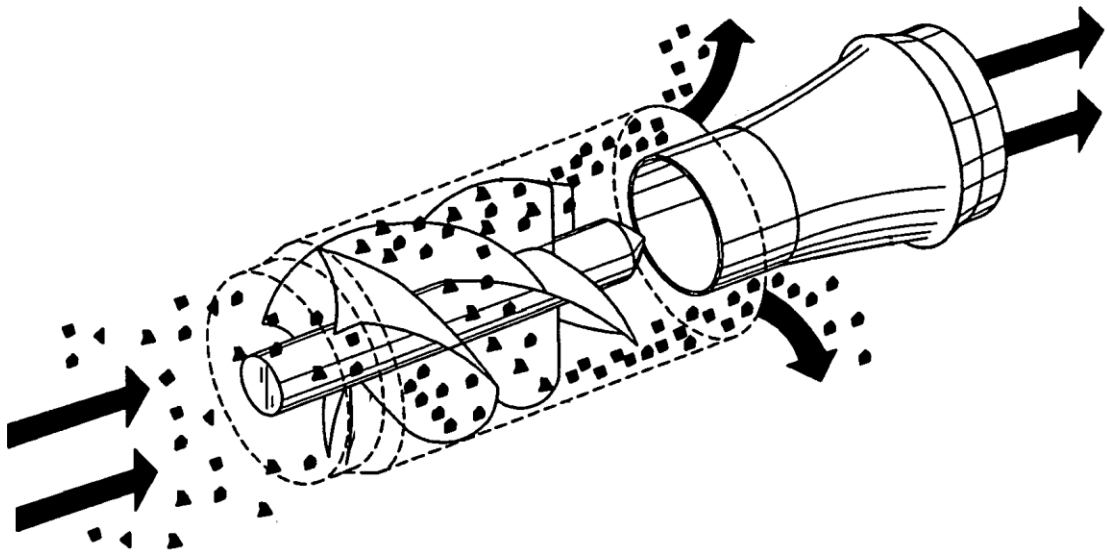
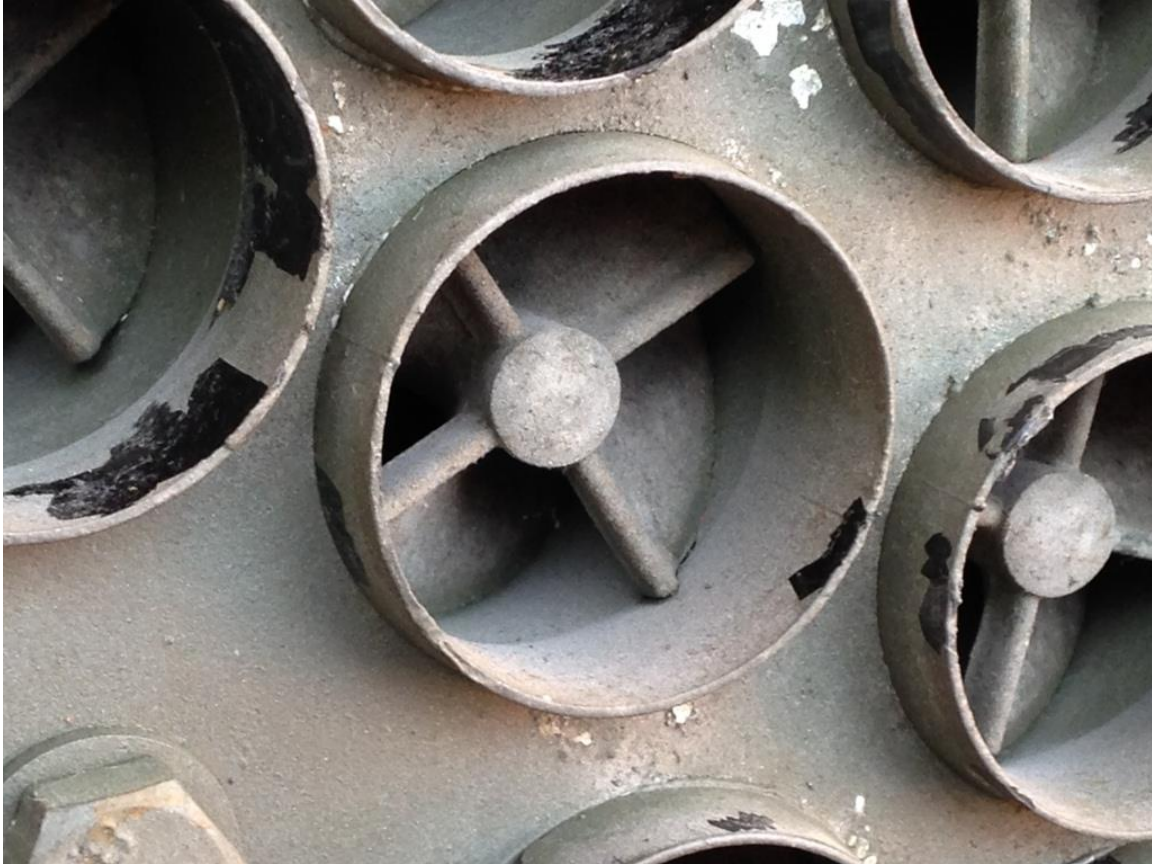

**A particle separator cell showing the air flow paths**

## Compressor

All small gas turbine engines are fitted with a centrifugal compressor. A centrifugal compressor consists of a rotating impeller wheel that throws the passing air outwards as it spins at high speed. Curved blades at the centre of the wheel, known as rotating inlet guide vanes (IGVs) form a type of fan which induces the air flow into the wheel at the frontal area, the air is then passed between diverging radial blades or vanes which guide the air outwards at a tangent to the rotational axis. In many small engines these blades are straight in shape radiating out from the rotational centre of the wheel, in certain designs the blades are curved back at the circumference of the wheel, this has the effect of improving the efficiency of the compressor.

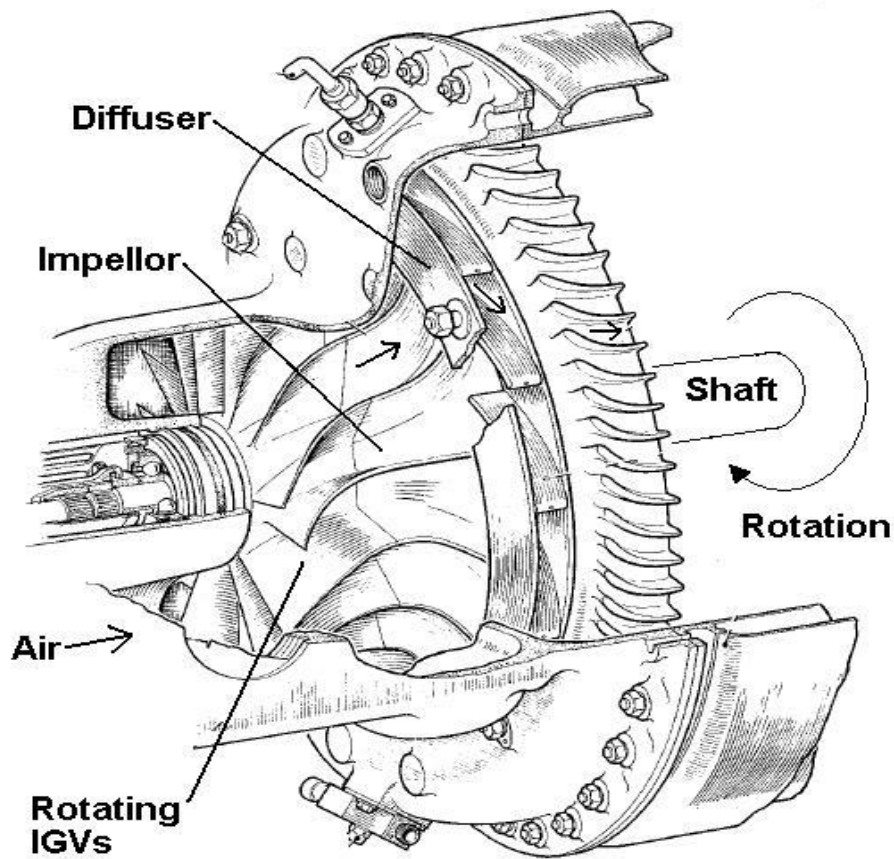

Typical compressor assembly cut away view

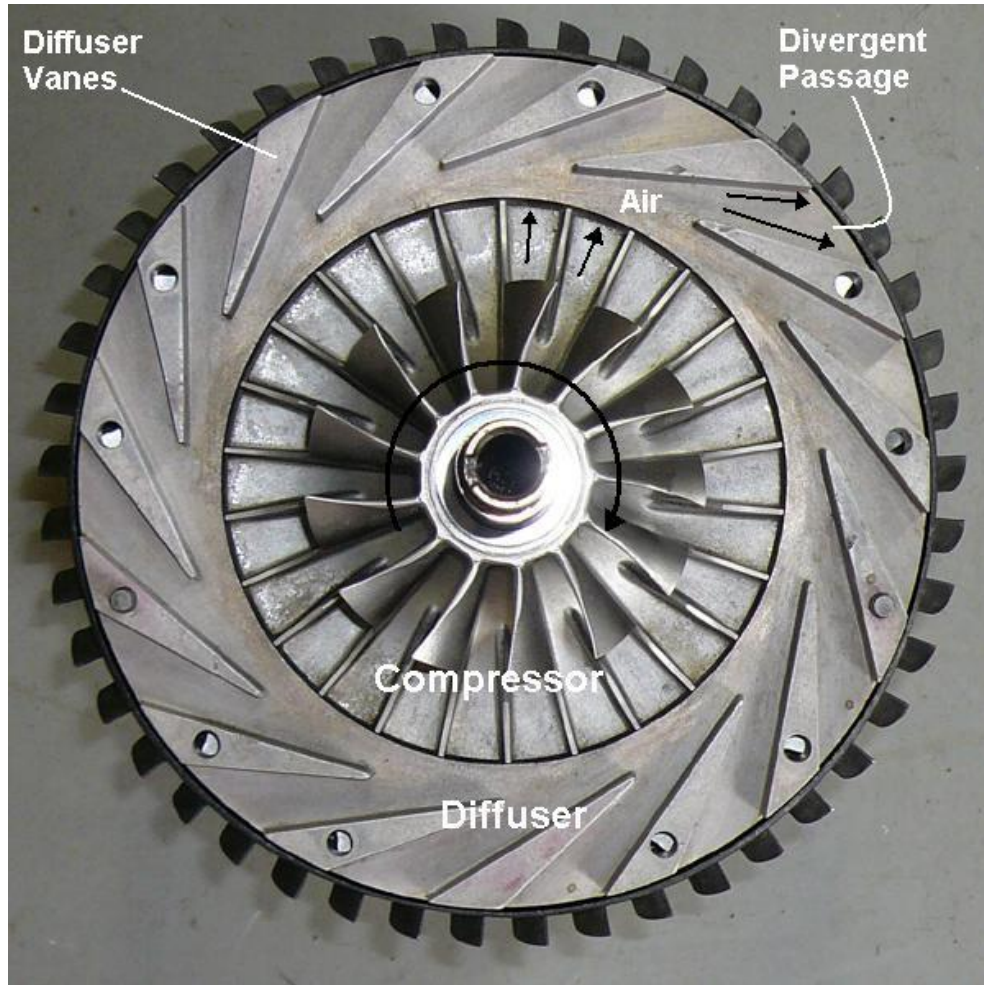

**Compressor diffuser showing divergent ducts (Casing removed)**

The compressor impeller is surrounded by a ring of stationary vanes or blades which receive very fast moving air from it. The air is "expelled" from the compressor into the region of vanes surrounding it, the device that does this is called a diffuser. The diffuser vanes slow down the air and remove some of the rotation from it, the effect of this is to raise the static pressure of the air. The passages between the vanes form many small divergent ducts through which the air passes, they slow down the movement of the air and the static pressure is increased. Air leaving the compressor diffuser sometimes travels between additional vanes, ducts or passages to further remove any rotational movement or swirl before it is passed to the combustion system.

## [Small Gas Turbines by Ian F Bennett](#)

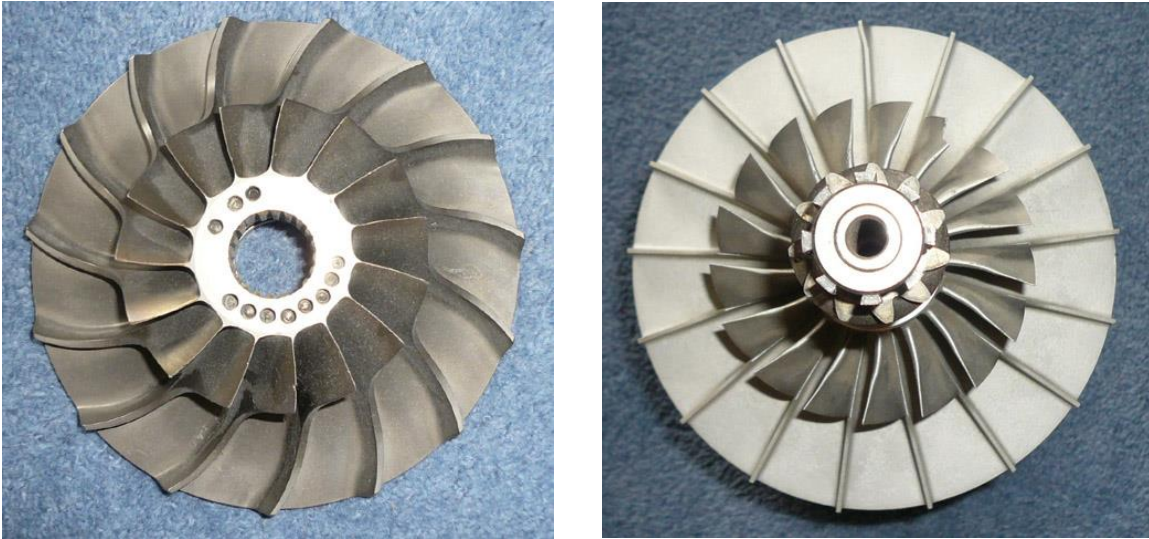

**Typical small gas turbine engine compressor wheels**

As the mass of air passes through the compressor system, the cross-sectional area through which it passes becomes reduced, thus a given amount of air occupies a smaller volume and hence the pressure has increased. The compressor can't really be considered on its own, it pressurizes the engine internal workings. A restriction on the compressor discharge is essentially created by the turbine nozzle. The combined effect of the rotating impeller and the stationary diffuser is to raise the air pressure by as much as four times that of atmospheric pressure (The pressure at the engine intake). To do this, the compressor has to rotate at very high speed, a wheel measuring about 5 inches in diameter may spin as fast as 60,000 rpm and in doing so considerable power is required to drive it. When the air is compressed inside the compressor mechanical work is done, absorbing energy, as much as two thirds of the energy developed in a gas turbine is used to drive the compressor. When air or any gas is compressed its temperature increases, this is because mechanical work is carried out upon it, air leaving a gas turbine compressor is raised in temperature for this reason. A typical compressor discharge pressure may be in the region 40 PSI and at a temperature of 180 degrees C.

The compressor rotor operates inside a casing that is normally fabricated from aluminum or magnesium alloy. The compressor case assembly may often incorporate a reduction or accessory gearbox and may also form the air intake area as well. A smooth convergent duct or bell-mouth is usually formed in front of the rotating central "eye" of the compressor to aid the airflow into it.

In order to get good efficiencies from small centrifugal compressors, the mechanical running clearances must be kept very small. The impeller must function with clearances of only a few thousandths of an inch between the rotating blades or vanes and the surrounding casing in order to prevent air leakage. The circumference of the compressor wheel runs close to the diffuser mounting assembly so that all the air flows into the diffuser and does not leak out, passes between blades and reduces the through-put efficiency. A gap exists between the actual diffuser blades tips and the tips of the rotating compressor blade tips, this is to prevent turbulence and allow for a smooth transition of

## [Small Gas Turbines by Ian F Bennett](#)

air into the diffuser. In order to prevent unwanted resonances, the numbers of blades or vanes mounted on the compressor wheel and the diffuser assembly are arranged to be dissimilar. A typical number of compressor blades may be 13 full blades and 12 half blades and 15 corresponding diffuser blades.

A type of compressor wheel exists called a shrouded compressor wheel. Here the issue of small running clearances and leakage may be partially mitigated by placing a rotating shroud around the compressor impeller vanes or around the rotating inlet guide vanes. The compressor casing could then be described as “rotating with it”. A labyrinth seal may also be employed to reduce air leakage. The shroud blocks air leakage between the impeller vanes and helps maintain efficiency. Shrouded or partially shrouded compressors may be found in some Garrett and early Rover gas turbine engines.

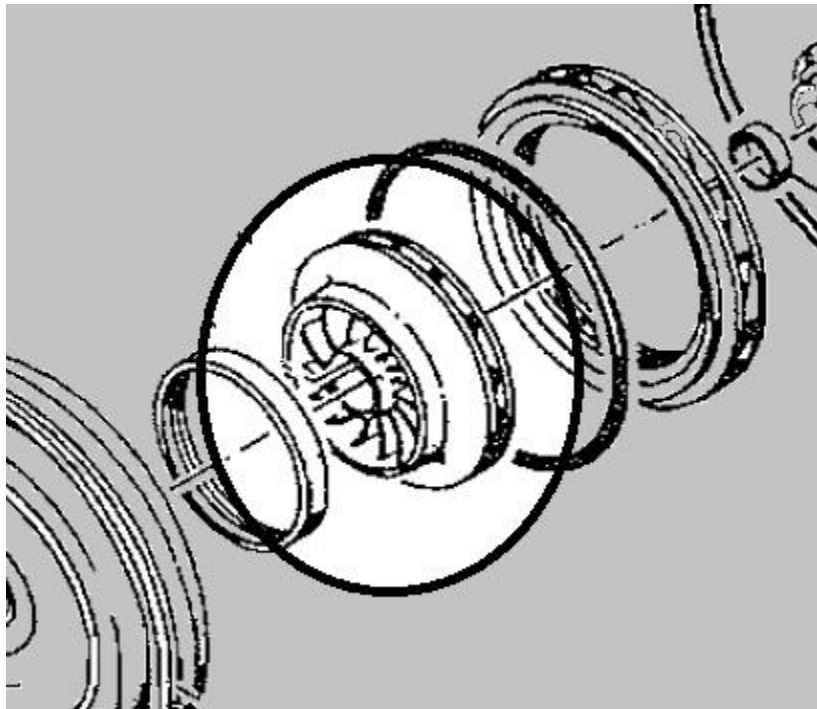

**Shrouded compressor wheel**

## [Small Gas Turbines by Ian F Bennett](#)

Compressor wheels are often made of grades of aluminum alloy, in many Garrett engines they are manufactured from Titanium. The rotating inlet guide vanes are sometimes manufactured from steel or stainless steel, in this case the compressor wheel is of a two-part construction. The rotating inlet steel guide vanes help guard against foreign object damage (F.O.D.). F.O.D. is caused when the engine ingests foreign matter during operation; particles ingested into the engine will cause damage to the compressor and possibly cause the whole engine to catastrophically fail. Particles may also become briefly trapped between the compressor and its housing as it rotates, this process can damage the internal surface causing scratches and scoring. Scratches and scores will increase the operating clearances of the compressor and hence reduce the efficiency of it. Air intake grills or meshes normally protect against F.O.D. (And probing fingers!), they should only be removed with caution. When a gas turbine engine is stationary and when in storage, it is good practice to blank off the air intake areas and the exhaust to further prevent the accidental ingress of foreign objects and contamination with dirt.

Aluminum compressor wheels are vulnerable to corrosion especially in older engines, engines which have been standing in poor storage conditions or engines of unknown history. It is always worth checking the compressor and intake area for corrosion and evidence of damp storage conditions. When inspecting the air intake area of a small gas turbine attention should be paid to the rotating inlet guide vanes, F.O.D may be indicated by gouges, nicks or even missing portions of blades. A gas turbine engine should never be operated with a damaged compressor as it may have become mechanically weakened and is out of rotational balance.

### **Air compressors**

The compressor system in many engine designs is deliberately made to operate at a larger capacity than that which is required to run the engine efficiently, this feature enables the engine to supply an external feed of compressed air. A portion of air flowing through the engine is bled off from the compressor before it reaches the combustion chamber, the feed of air delivered although at only moderate pressure (45 PSI) exhibits high mass flow (Large volume of air per second flowing) and so contains high kinetic energy, this is sufficient to drive a small external turbine. This supply of compressed air may be used for aircraft engine starting or cabin air-conditioning. Many gas turbine engines are designed to provide compressed air and shaft horsepower simultaneously, usually the shaft output is de-rated during air bleeding. The engine is de-rated because less air flow is available within the engine to keep it cool below safe limits.

## Small Gas Turbines by Ian F Bennett

The Blackburn Palouste engine discharges air as it runs, and the air bleed is only shut off during starting by a special valve. During starting, the compressor efficiency is very low so the airflow through his engine has to be maximized to prevent it from overheating.

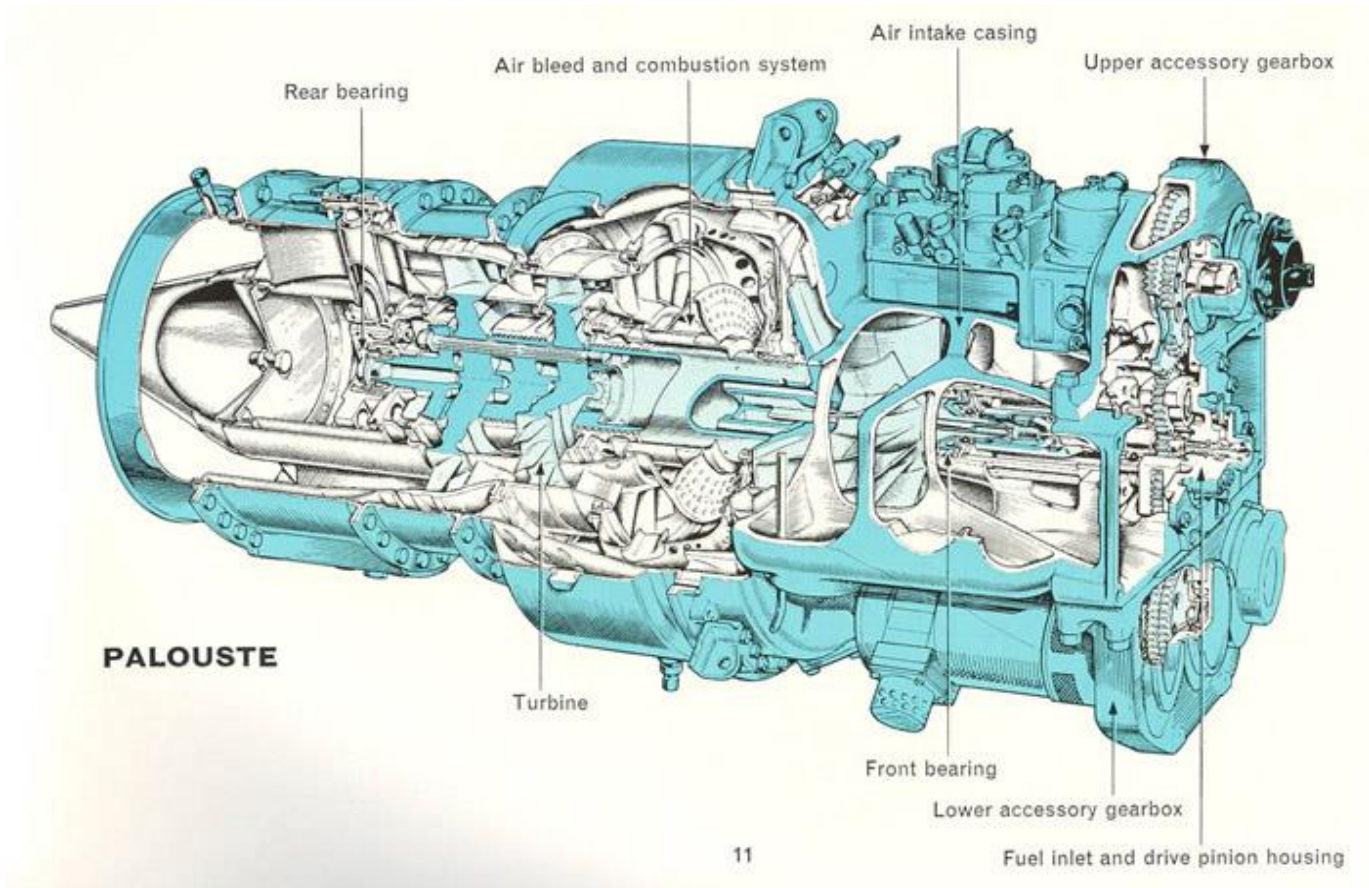

### **A gas turbine engine equipped with a compressor air bleed**

Certain versions of the Rover 1S series gas turbine are equipped with an air valve which is closed during starting and normal running, when an air supply is required the valve is opened.

Small air compressor bleeds (A few percent of total mass flow) may be used with venturi devices to induce greater quantities of air flow for the cooling of devices such as oil coolers or electrical generators.

The Rover 1S60 fire fighting water pump unit employed an air bleed to aid in the priming of the water suction hose.





**Small gas turbine featuring compressor air bleed (Microturbo)**

Another air bleed engine the French built Microturbo Saphir discharges air continuously at all speeds even during start up, this engine is sometimes referred to as an "Air Generator" or "Air Producer".

[Small Gas Turbines by Ian F Bennett](#)



**Gas turbine compressor unit used for larger engine starting**

[gasturbineworld.co.uk](http://gasturbineworld.co.uk)

**Compressor surge-**

The compressor of a gas turbine is designed to work within a range of operating conditions and parameters. The engine must initially start, promote stable combustion, accelerate to self-sustaining speed and obtain full load speed without the compressor malfunctioning. The compressor “pumps” air through the engine, the passages and components through which the air and combustion gases travel create a restriction and hence a “back pressure” is placed upon the compressor outlet. The compressor is “loaded” by these components. A situation may occur in a gas turbine where the compressor load becomes too great for it to function correctly, and aerodynamic failure occurs within it and the pressure rise through it momentarily collapses. This condition is known as compressor surge or stall and may also be likened to “cavitations” inside the compressor. Compressor surge may occur during starting or acceleration phase if too greater amount of fuel is supplied to the engine and the subsequent expansion in the combustion process overloads the compressor as it fails to escape through the turbine nozzle. Compressor surge is characterized as popping, sudden bangs, fluttering or low frequency buffeting sounds. A small engine may recover from compressor surge as the operating parameters fall back within the range of the compressor and stable running resumes. Severe cases may cause the combustion to extinguish (Flame out) or the engine fails to recover altogether and has to be shut down quickly and then restarted. Compressor surge rapidly reduces the mass of air flowing into an engine, normally this will cause a loss in power and the exhaust gas temperature to rise, if unchecked, this will cause damage to the engine. Common causes of compressor surge include, malfunctioning fuel control systems, incorrectly set up air bleed systems and dirty, damaged or fouled compressor components. Sudden transient changes to compressor loading (i.e., opening and closing bleed systems) may also give rise to compressor surge.

**Individual compressor stage loading:**

The tendency to compressor surge and stall may be reduced by decreasing the load and variation placed upon the compressor stage or stages within the engine. Many small gas turbines employ only one compressor stage. This stage is normally loaded close to its surge limit, particularly in the case of air bleed engines which are required to deliver a given mass flow and pressure for external use. It is possible to construct two tandem centrifugal compressor stages (one feeding into another) and operate them at lower individual stage load to reduce the tendency to surge. Some models of Garrett engine (GTCP85) use a two-stage compressor to produce a pressure rise of some 45 PSI and operate a simple on-off bleed valve arrangement. This engine can cope with the changing air bleed demands. A similar bleed of air is obtained from a single stage Palouste MK102 engine, due to the single stage, a calibrated regulating bleed valve system is needed to manage the airflow through the engine and prevent surging.

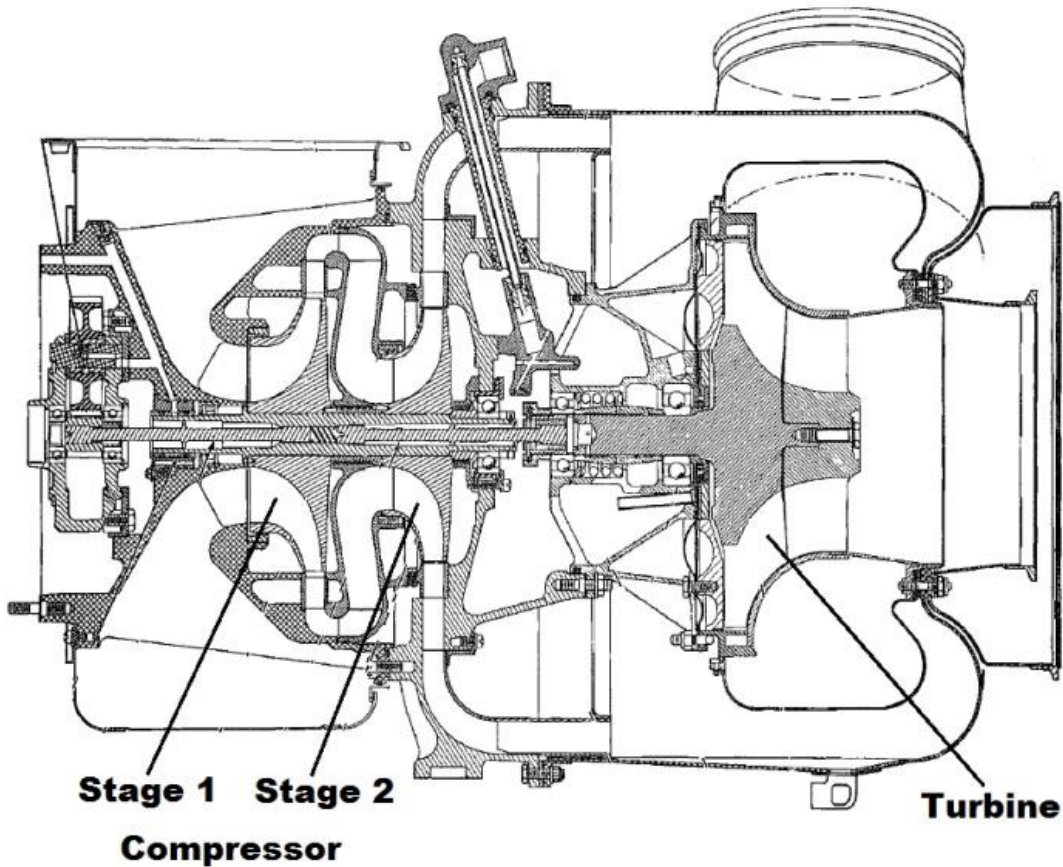

**Gas turbine engine featuring a twin stage compressor**

[Small Gas Turbines by Ian F Bennett](#)

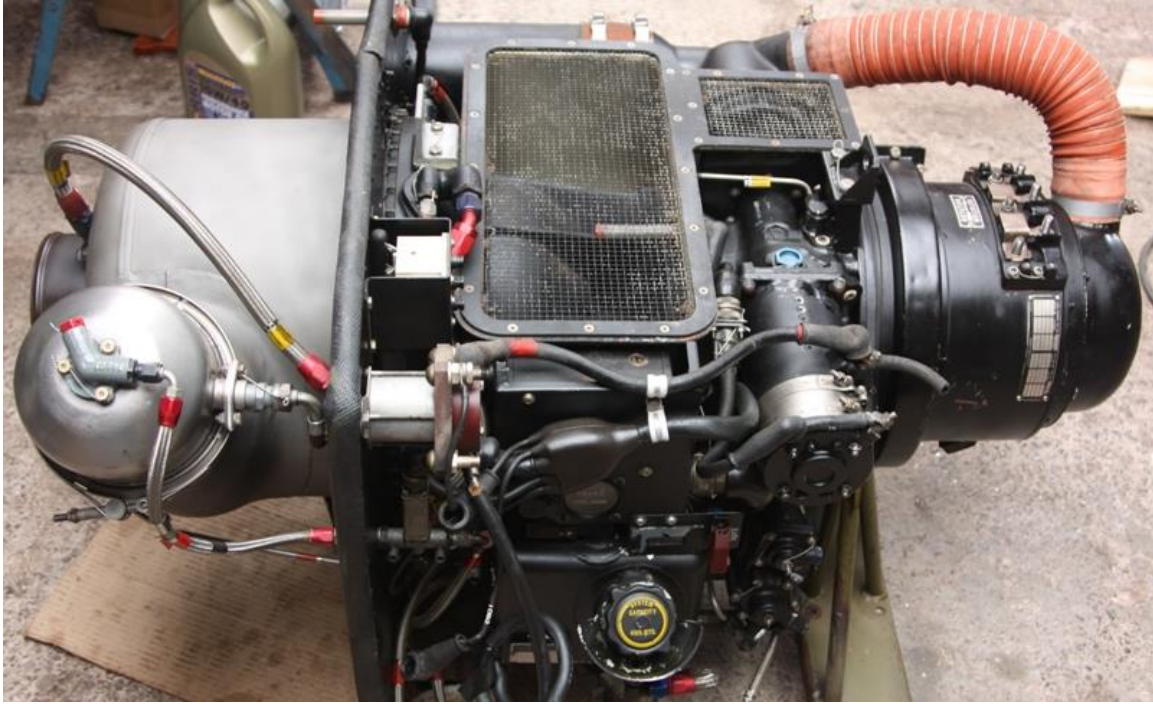

**Twin stage compressor: Garrett GTP70 APU**



**Compressor bleed valve (Palouste)**



**Compressor bleed valve (Garrett GTCP85)**

### **Compressor washing-**

Over an extended period of use, the compressor components in a gas turbine engine may become dirty or fouled. This will depend on the atmosphere or environment in which the engine is operated, a buildup of dirt or deposits from ingested airborne material can occur within the compressor rotor and diffuser assemblies. It is possible to clean an engine compressor without dismantling the engine. The engine may either be run off-load or rotated at starting speed and a special compressor washing compound sprayed into the compressor air intake. The compound may consist of a mixture of solvents and distilled (de-ionized) water or a proprietary compressor washing fluid may be used. In each case the engine manufacturer's recommendations should be closely followed. In the past, trichloroethylene solvent has been recommended for compressor washing, this substance is now banned from sale and use, but if still used extreme caution must be exercised. When this solvent is passed through the combustion process of the engine, it creates a poisonous gas in the exhaust that must not be breathed in!

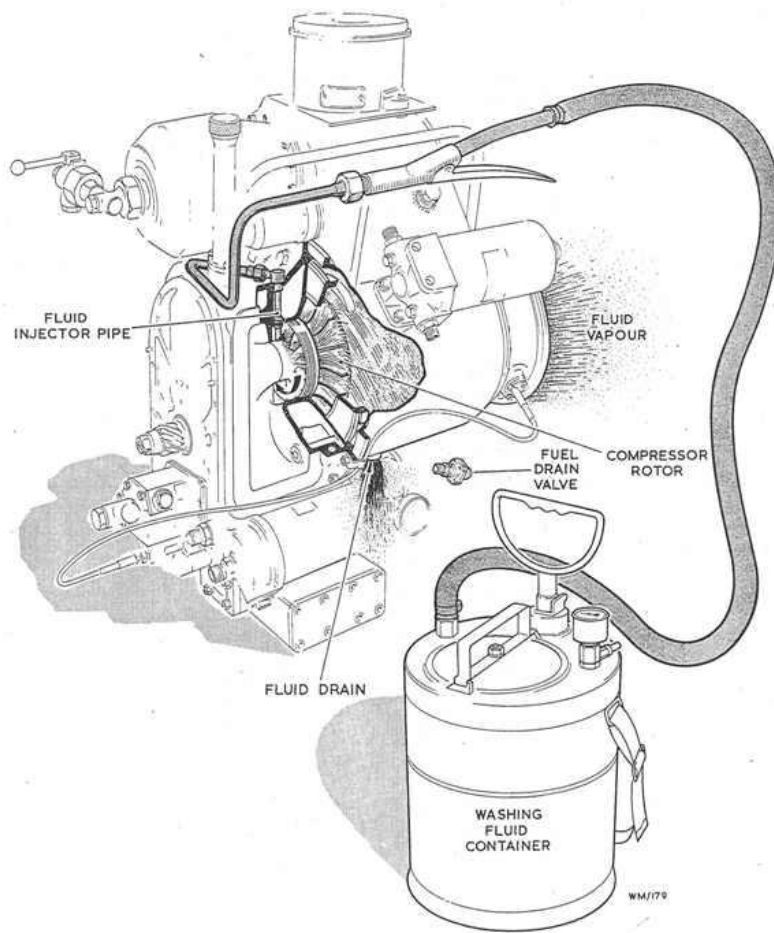

**Compressor washing with fluid (Rover 1S60)**

## Small Gas Turbines by Ian F Bennett

### **Combustion system**

Air emerging from a gas turbine compressor diffuser is passed to the combustion system where it is heated by the burning of fuel; this process provides the heat energy that drives the working cycle of the engine. In the combustion chamber the heated air expands, gains kinetic energy, and the pressure remains almost constant. It is the heat input to the gas turbine cycle that propels the engine, normally a flame provides this heat, however if some other form of heat input could be obtained e.g. an electric heater or heat exchanger (Feed from an external heat source) with sufficient capacity the engine would run. In practice the heat required in the small space of the combustion chamber is best provided by a flame with a central temperature of over 2000 degrees C.

The combustion arrangements in small engines basically consist of three types, a can type, an annular type or a radial type.



**1. Can type combustion chamber (Combustor).**

This is the simplest of combustion arrangement and consists of a cylindrical metal can shaped housing containing a heat-resisting alloy metal liner or flame tube. Air from the compressor is ducted to the combustion chamber by the casing surrounding the compressor diffuser outlet. This casing may surround all the hot parts of the engine and hence reduce the outside surface temperature to an acceptable level.

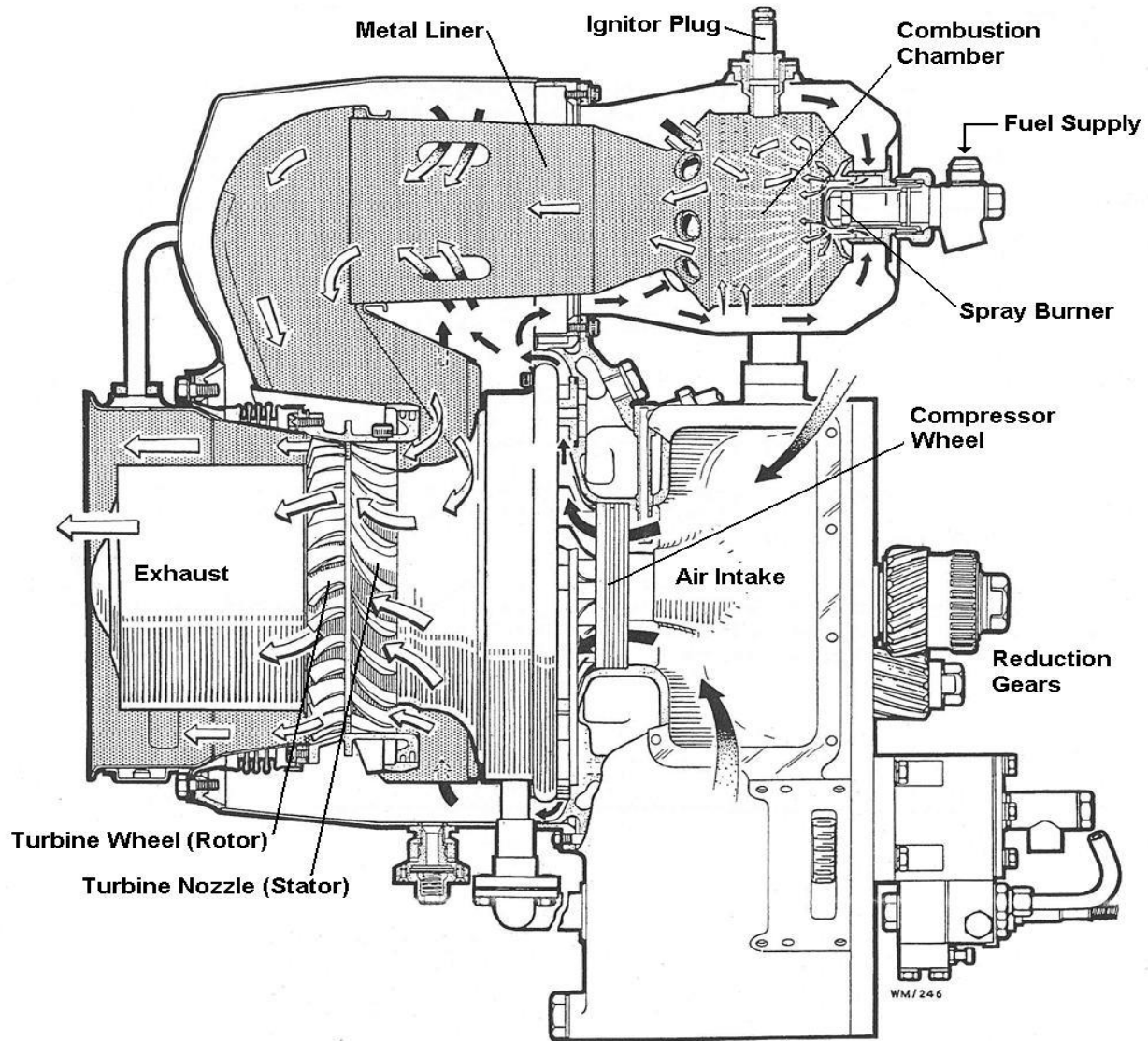

**Small gas turbine engine incorporating a can-type combustion chamber**

The combustion chamber liner consists of a heat resistant metal cylinder that is closed at one end by a dome shaped cap. Fuel is admitted to the combustion chamber in the form of a finely atomized spray from a nozzle at the closed end where it is ignited by a special

## [Small Gas Turbines by Ian F Bennett](#)

spark plug. Air from the compressor flows around the outside of the liner and between it and the outer combustion chamber casing. A series of holes or orifices in the liner admit the air into the central region of the liner where it mixes with the fuel, burns and sustains combustion. The burnt exhaust gases exit through the open end of the liner and are ducted to the turbine assembly. The holes in the liner are arranged to provide air for the combustion of the fuel and additional larger holes towards the open end admit more air for cooling of the combustion products. The flame temperature inside the liner may reach some 2000 degrees centigrade, this is too high for the hot section parts of the engine (Turbine Nozzles, Turbine and supports) to cope with and so the additional dilution cooling air is required to bring the temperature down. A typical turbine inlet temperature may range between 400-900 degrees centigrade depending on the type of engine and the load placed upon it. Only about 25% of the air entering a gas turbine is burnt with the fuel, the rest is used for cooling. The detailed arrangements of the holes becomes complex, they are required to produce swirl within the liner and stabilize combustion over a range of operating conditions. The surface of the liner is also kept cool by rings of very small holes that provide a protective boundary layer of cool air within the combustion chamber liner. The hole or orifice sizes are arranged so that the pressure drop between the outside and inside of the flame tube is kept to a minimum; any drop in pressure at this point will reduce the efficiency of the engine and place an unnecessary load upon the compressor.

The flame tube/liner arrangement holds a stable flame within the combustion chamber which unlike a piston engine, burns continuously. The pattern of airflow around the fuel nozzle is carefully arranged so that a turbulent recirculation motion thoroughly mixes the air and fuel spray together and anchors a stable flame in place. Ignition of the fuel is only required once during the starting of the gas turbine engine.

The flame tube is made of a corrosion and heat resistant metal such as stainless steel or a high temperature nickel-alloy such as Nimonic. Over a period the tube may become distorted due to thermal stresses and heat cycles. Small amounts of distortion depending on the engine type may be permitted. Cracks due to thermal shock and fatigue can also form in the flame tube and often between the holes and orifices, these may be repaired by welding (detailed in the manufacturer's overhaul or maintenance manual) if not severe. The overhaul or maintenance manual for a particular engine will normally detail acceptable limits of distortion and cracking for the combustion chamber and hot section components.

The combustion chamber liner will be suspended at several points inside the engine. The liner will normally be allowed to "Float" slightly and may appear loose, and rattle slightly, this is to allow for thermal expansion and so prevent the liner from distorting unnecessarily.

During the prolonged operation of the combustion chamber, carbon deposits may build up in the flame tube and around the burner nozzle. Depending on factors such as fuel type and burner design, carbon deposits will build up and the combustion process detrimentally effected. Carbon formations around the burner upset the fuel spray pattern

## Small Gas Turbines by Ian F Bennett

and reduce the atomization quality. Carbon deposits may also block or modify the air holes, this leads to less efficient air distribution. If the spray pattern is very poor the resulting flame may continue outside the combustion chamber area and create an uneven temperature distribution around the turbine and associated components, this will lead to the eventual burning of these components and failure. It is possible to "De-carbonize" combustion chamber components, great care is needed as devices such as fuel burner nozzles and igniter plugs should be not brought into contact with abrasive materials or tools.

Igniter plugs and burner nozzles should only be cleaned with soft materials soaked in mentholated spirit or electrical cleaning solvents.

A single can type combustion chamber exhibits a few advantages over other types. The main advantage is simplicity, a single burner is installed in the engine and the liner can be easily removed for inspections and maintenance. In small engine designs, achieving efficient and complete combustion becomes difficult as the internal dimensions and burning length required are relatively small. A cylindrical can type chamber holds a single relatively large flame for a given size of engine.

The disadvantage of a can combustor is that the engine may not be found to be as compact as with other types. The engine will not be symmetrical about its axis, for some small starter units that may be mounted on larger engines, compactness, weight and minimum external dimensions are important.

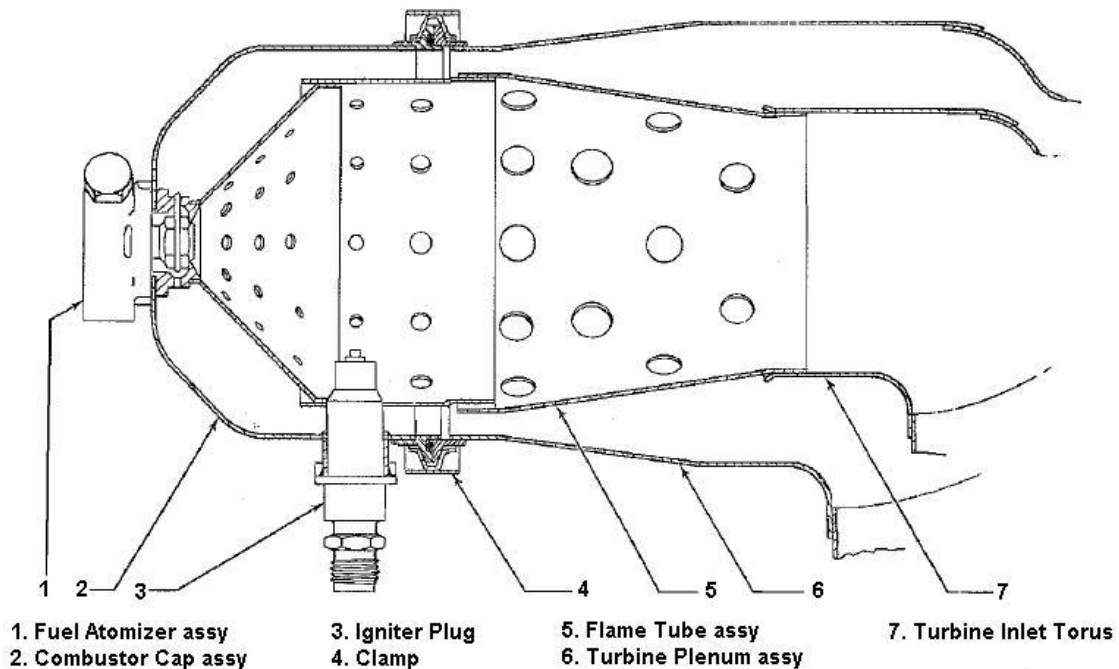

**Can type combustion chamber inc. Atomizer and igniter plug**

## Small Gas Turbines by Ian F Bennett

A single can-type combustion chamber is fitted to many Garrett engines and also the Rover 1S series uses a single can combustion chamber. The Perkins Mars/Solar T41 is another gas turbine which employs a single can type combustor. Occasionally engines use two can type chambers mounted diagonally opposite each other, an engine once built by the company Auto Diesels is constructed in this way.

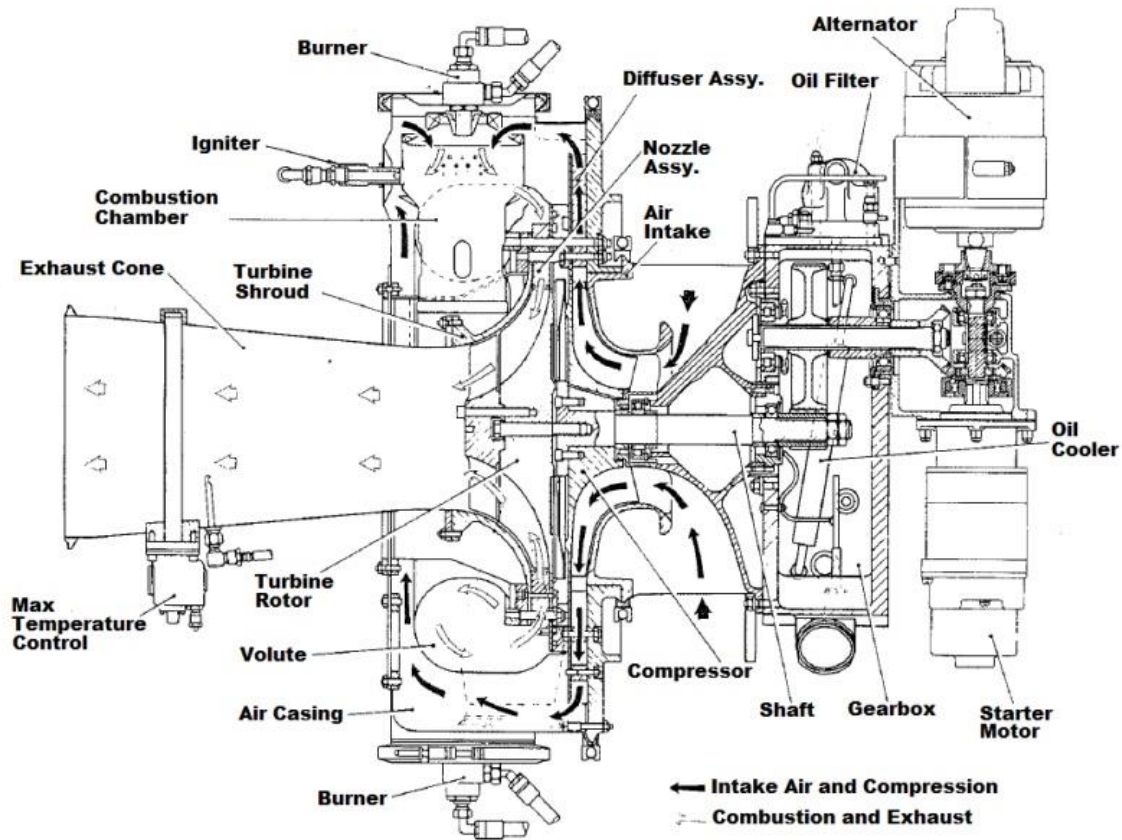

**Twin combustion can engine (H & S Stad 250)**



**Hants and Sussex STAD250**

[Small Gas Turbines by Ian F Bennett](#)



**Can-type combustion chambers (Garrett)**

## 2. Annular combustion chamber

An annular combustion chamber is required to do exactly the same function as a can-type unit but is physically arranged in a different way to reduce the overall size and form of the engine. The combustion chamber liner forms a toroid or "doughnut" shape and is wrapped around the axis of the engine. Instead of a single fuel burner nozzle a ring of multiple fuel nozzles are deployed. The combustion chamber liner is often arranged to curve the combustion gases back on itself, in which case it is referred to as a "reverse flow combustion chamber". A reverse flow combustion chamber saves on the overall length of an engine and provides a longer burning area for the gases to travel through.

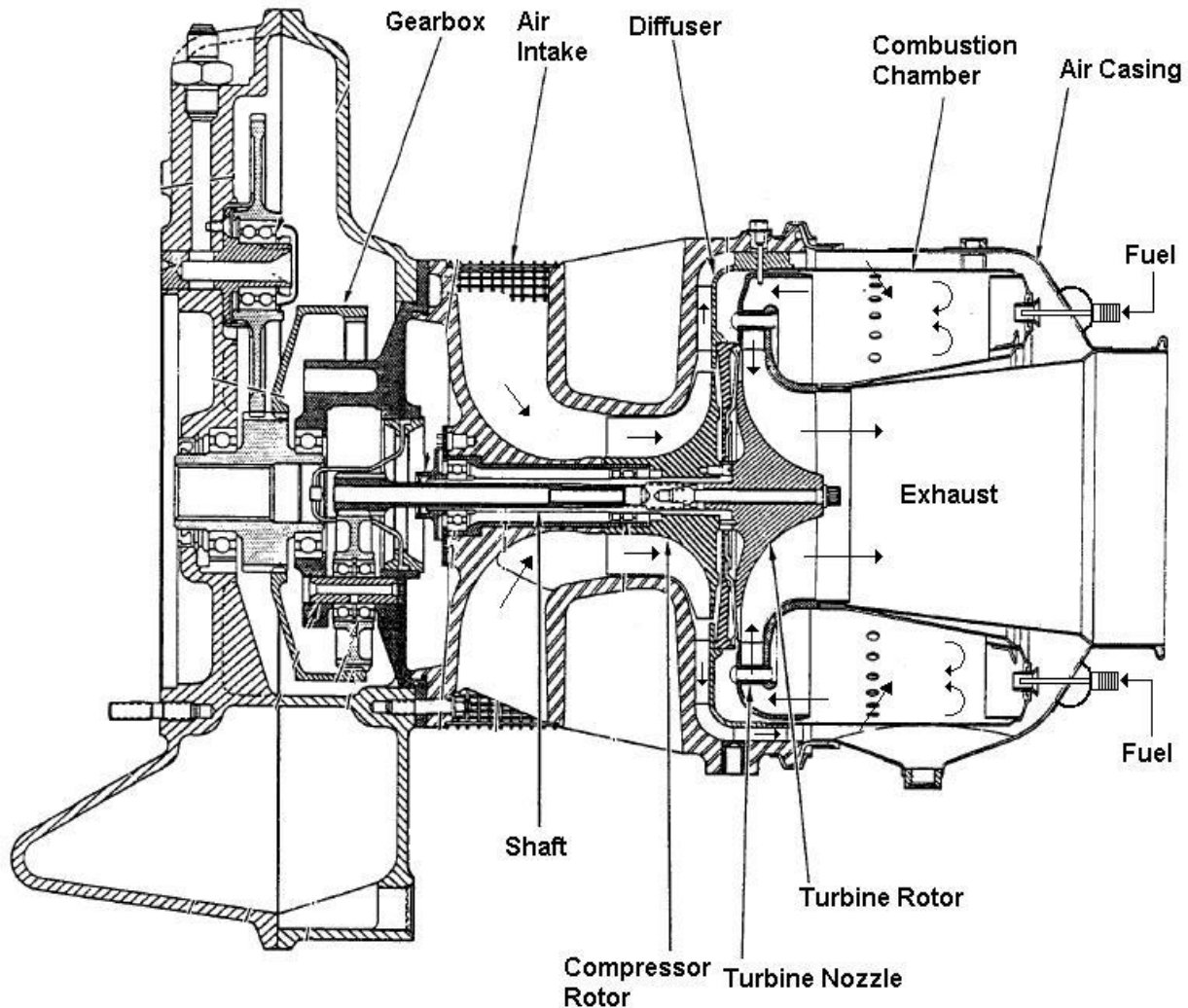

**Small Gas Turbine engine incorporating an annular reverse-flow combustion chamber**

## [Small Gas Turbines by Ian F Bennett](#)

The reverse-flow combustor and reduced length engine may be important in allowing a shortened rotational shaft that interconnects the compressor and turbine. The rotational shaft dynamics may be improved by a short, stiff shaft and closer spaced bearings.

The annular reverse flow combustion chamber arrangement requires several fuel burner nozzles to be placed at the back of the engine around the exhaust circumference. Fuel is distributed to the burners by a pipe manifold or by drillings in the combustion chamber outer casing. The spray patterns from the individual burners are of a cone or fan shape or in the case of a Lucas aerospace engine, five burners produce flat fan shaped patterns that are arranged in the form of a pentagon. One or more igniter plugs are placed next to the burners to initiate combustion, once one burner lights up the flame spreads to the others rapidly.

Air holes are placed in the combustion chamber liner in a similar manner to that in the can type system. Small holes in the nozzle/burner region provide air for combustion and then larger holes down-stream provide cooling dilution air before the gases are passed to the turbine system. Air that has been bled from the compressor may also be supplied to the burners directly to assist in the atomization process.

The annular combustion chamber reduces the overall size of an engine but it is more integrated into the engine construction and is therefore often more difficult to remove, service and inspect.

The Rotax/Lucas Aerospace gas turbine starter/auxiliary power unit uses a reverse flow combustion chamber with five burners. The Microturbo Saphir and the related Plessey Dynamics "Solent" gas turbine starter also uses a reverse flow arrangement with eight burners. The Solar T62 "Titan" unit is fitted with a reverse flow combustion chamber and six vaporizing burners plus torch igniter.





**Annular combustion chamber (Lucas)**

### 3. Radial combustion chamber

A third type of combustion system consists of a radial layout. The radial combustion chamber was pioneered by the French company Turbo-Mecca and can be found in a number of their designs. The German company Man-turbo (MTU) formally BMW, The American company Williams Research and the Swiss company Saurer also used this combustion chamber layout.

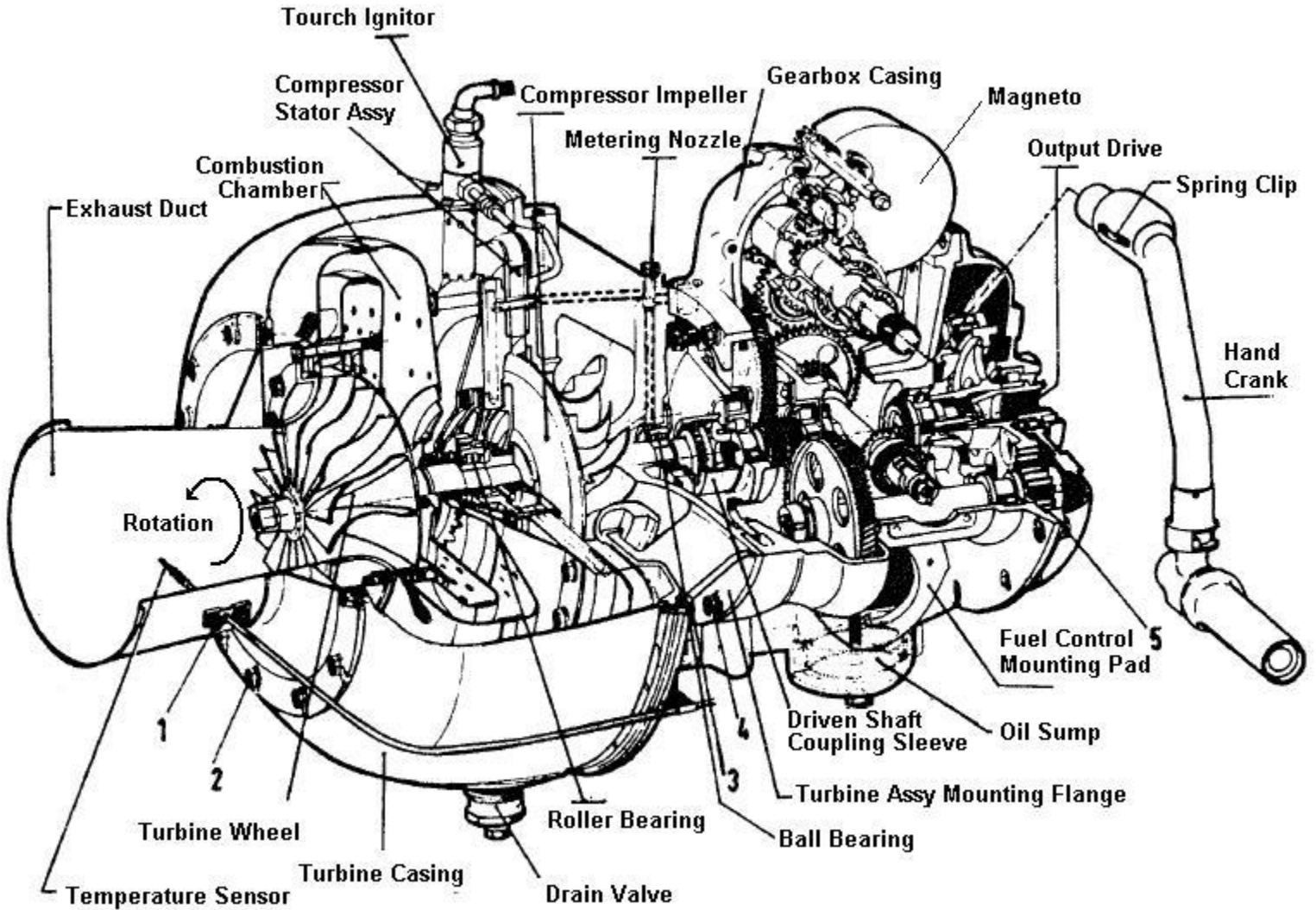

**Small gas turbine engine fitted with a radial disc type combustion chamber (MAN6012)**

The combustion chamber liner is arranged to form a radially disposed chamber around the shaft that connects the compressor to the turbine, fuel is first passed into ducts inside the shaft. The fuel is then admitted into the combustion chamber through the turning shaft from a series of radial drillings placed in it. As the shaft rotates at high speed, the fuel is

## [Small Gas Turbines by Ian F Bennett](#)

thrown outwards from the drillings and a fine disc shaped spray pattern results. The fuel spray is ignited and burned with a similar combustion air and cooling air distribution ratio to that of the other combustion chamber types. The air distribution is created by holes and orifices forming rings in the combustion chamber liner walls around the shaft axis. The hot gases from the combustion process are guided by the liner outwards and along the engine axis or back towards the centre depending on the type of turbine wheel used. The whole radial liner is enclosed in an outer casing that is pressurized (and cooled) with air from the compressor.

Fuel has to be supplied to the combustion chamber through the engine shaft, this requires a seal arrangement at the cold end near the compressor to ensure that it does not leak out into the other engine systems i.e., the oil supply to the bearings.

The Blackburn Palouste, Artouste and Nimbus engines all use this arrangement, as do other Turbo-Mecca engines and some Continental US built units. The radial layout makes for a symmetrical engine around its axis similar to the annular combustion chamber layout. The fuel pump required needs to maintain only moderate pressure, however due to centrifugal force generated by the high rotational speeds, the actual injection pressure into the combustion chamber is very high. A high fuel pressure helps to aid the atomization process for a cleaner and more complete fuel burn.

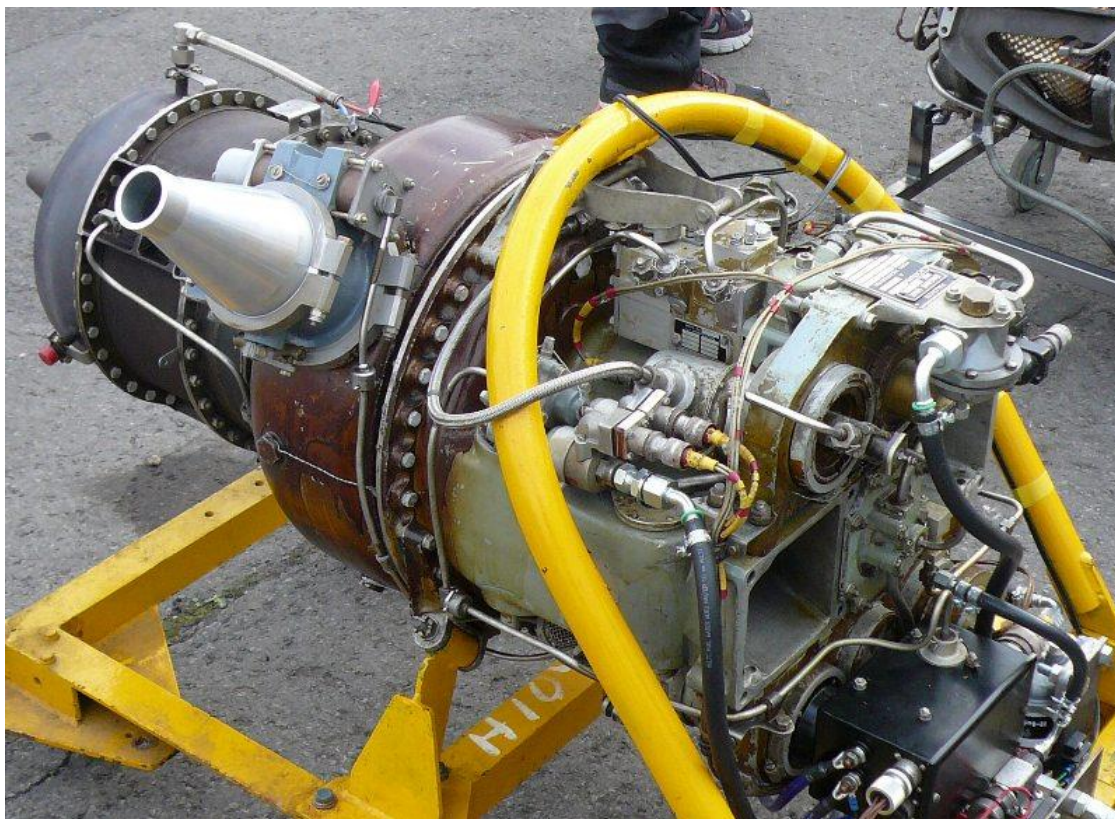

**Blackburn/Rolls Royce Palouste engine**

**Mechanical layouts**

Most small APU size gas turbine engines adopt a simple single shaft layout, that is the compressor turbine also drives the load. The overall mechanical layout is dependent on the type of combustion chamber and turbine or turbine(s). Several differing configurations are possible with these components and various manufacturers favor differing layouts.

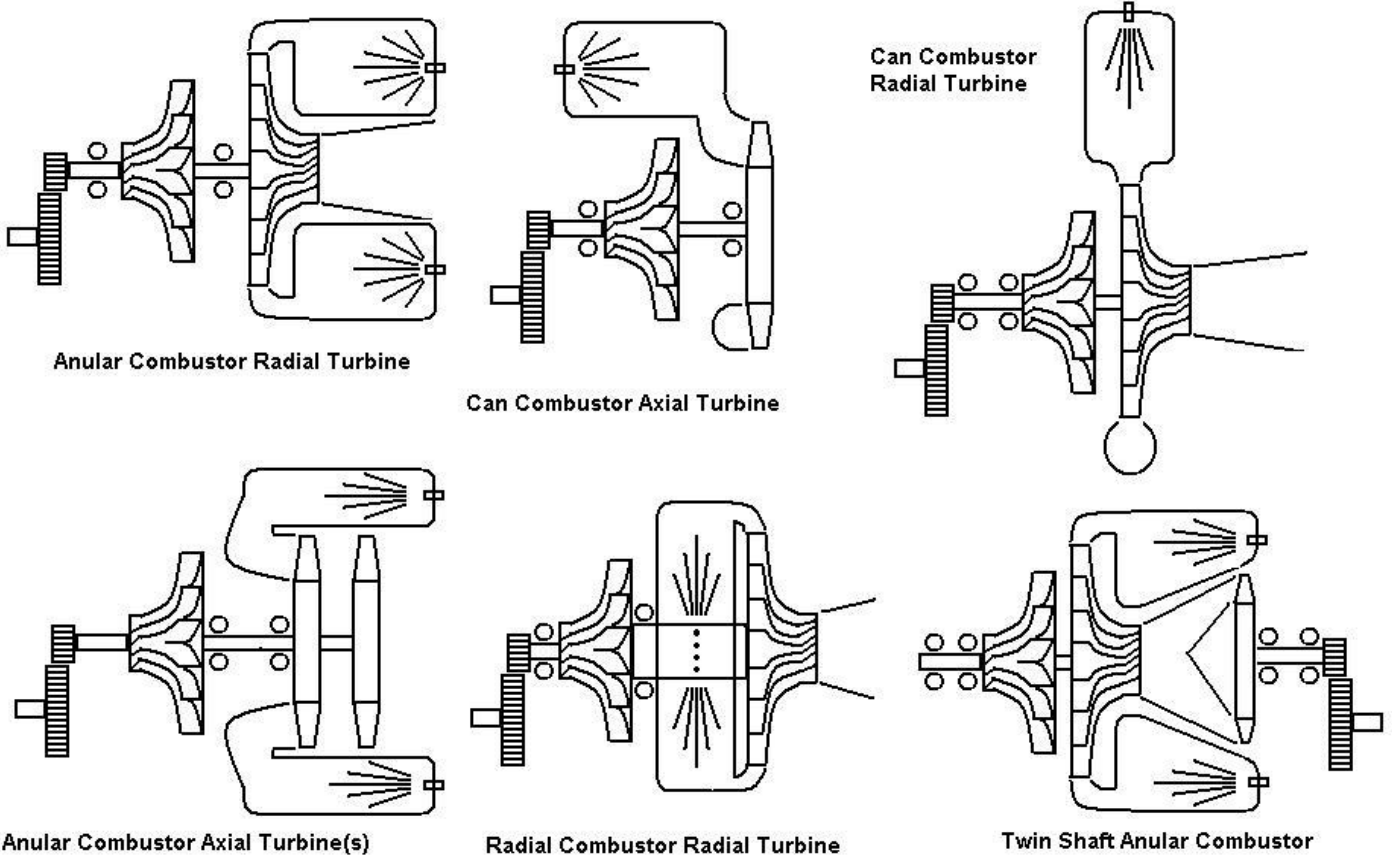

**Typical small gas turbine engine mechanical layouts**

## Small Gas Turbines by Ian F Bennett

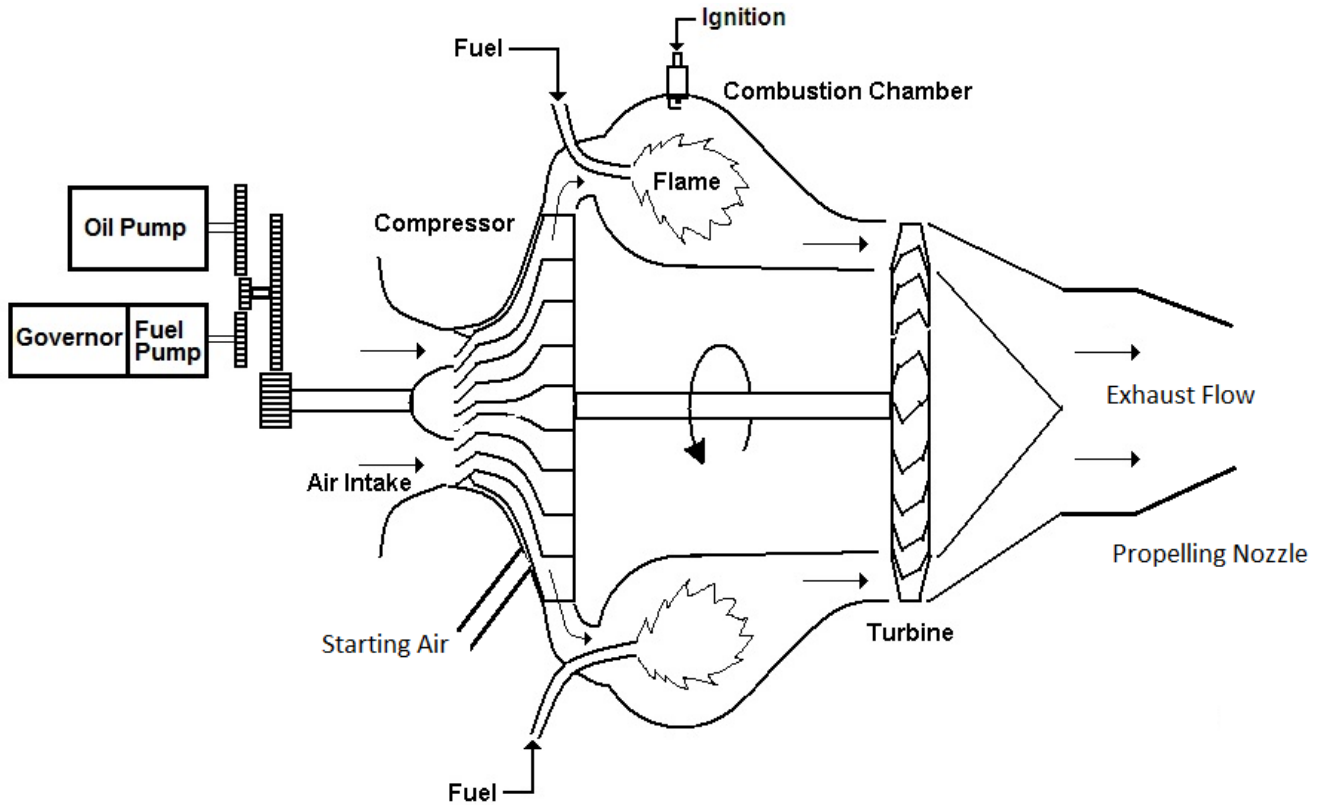

**Working diagram of a simple turbo-jet engine**

Gas turbines are often classified as “Turbojet”, Turbofan” or “Turbo-shaft” engines, small APUs are generally considered to be turbo-shaft units. Small turbojets intended for the propulsion of UAVs (Unmanned Aerial Vehicles) and drones are similar in design to APUs and in some cases have been derived from them. The Rover TJ125 also known as the Lucas CT3201 is a development of the twin shaft 2S100 series APU size unit.

Small Gas Turbines by Ian F Bennett



**Rover TJ125/Lucas CT3201 Turbojet**

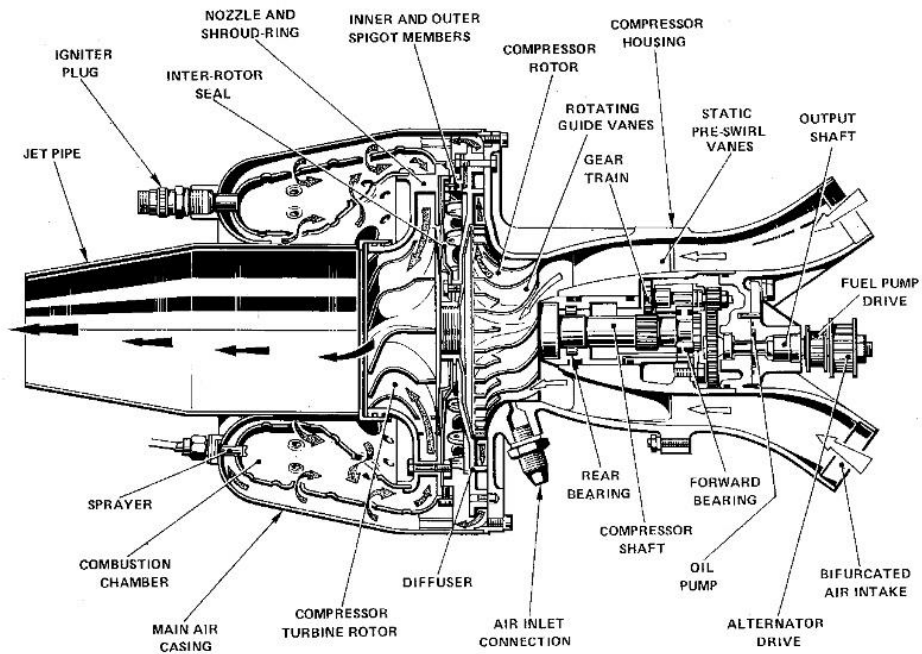

**Lucas CT3201 layout (reverse flow combustor + radial turbine)**

## Turbines

The turbine wheel or wheels in a gas turbine serve a number of purposes, in all cases one or more turbines are used to drive the compressor via the connecting shaft, this is what sustains the engine operation. External power from the engine may also be obtained from this shaft (via a reduction gearbox) or an additional turbine is used which is mechanically free from the turbine driving the compressor.

There are two types of turbine that are used in small gas turbine engines, the radial-inflow turbine and the axial-flow turbine. Depending on the design of engine either type can be found, notably in the Lucas Aerospace GTS/APU and Rover 2S150 both types are used in the same engine.

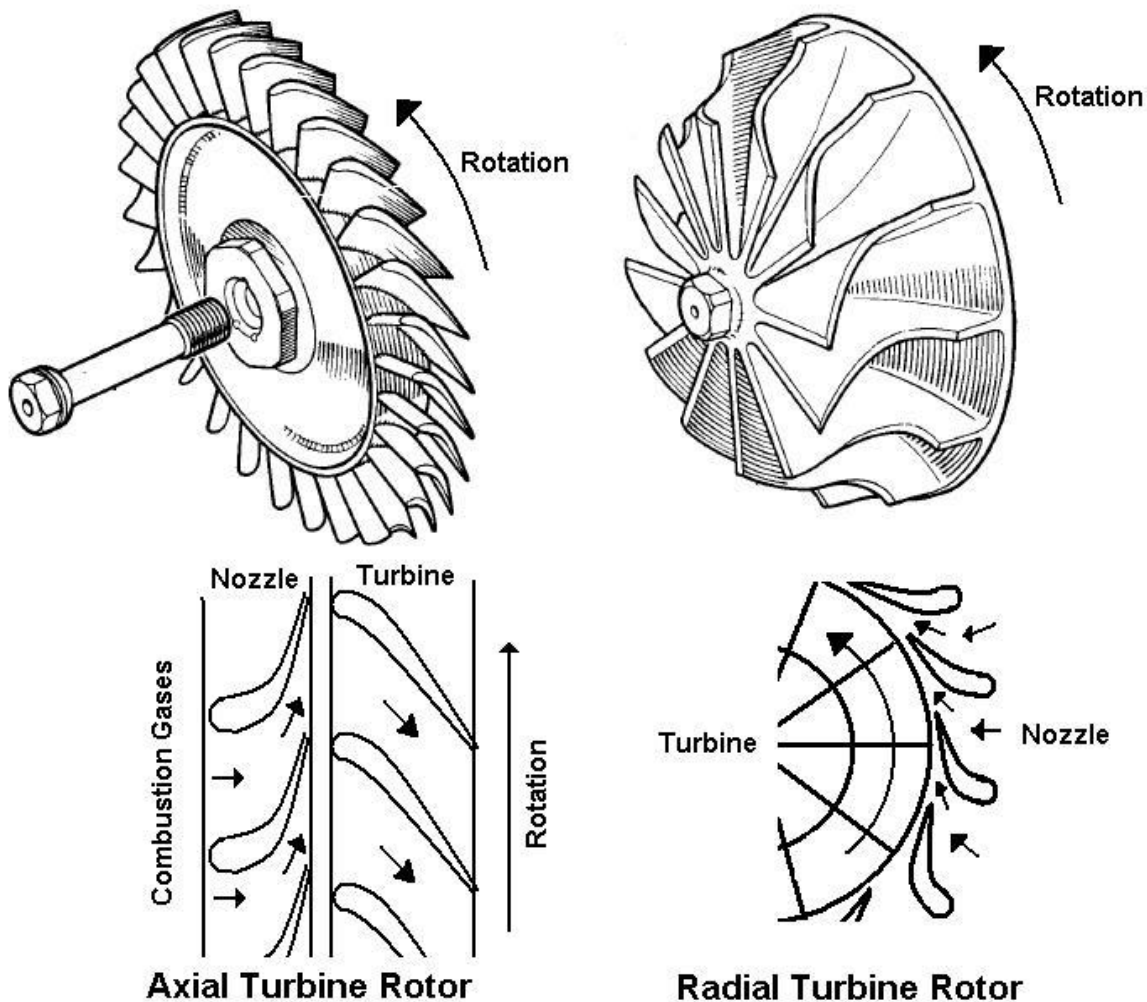

Types of turbine wheels found in small gas turbines

[Small Gas Turbines by Ian F Bennett](#)

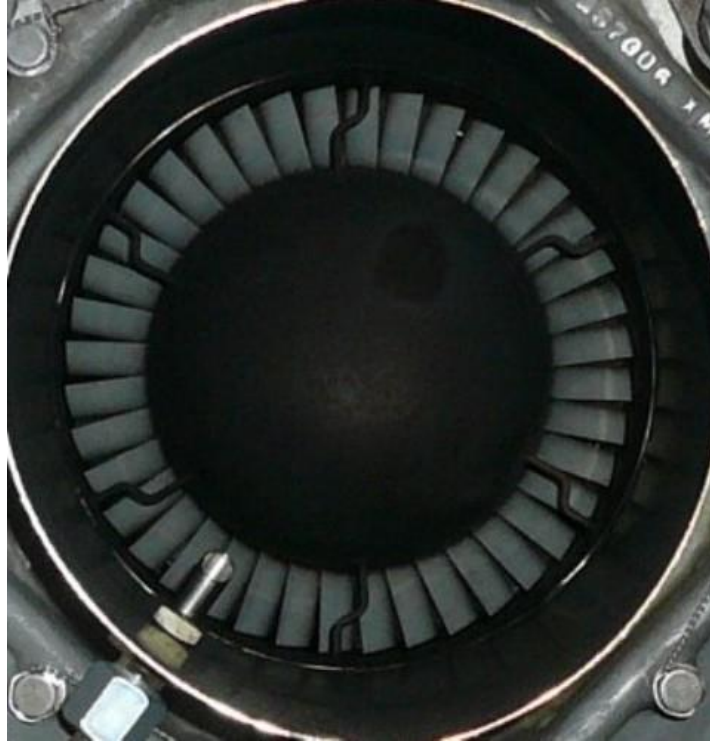

**Axial flow turbine exhaust view**



**Radial flow turbine exhaust view**



### **Axial flow turbine**

The axial flow turbine wheel consists of a wheel with a number of small, angled blades mounted around its circumference. The hot expanding gases from the combustion chamber are directed onto the blades by a ring of similar static blades or vanes forming a nozzle. The passage between the blades forms many small nozzles which ensure that the gases impinge on the turbine blades in the direction of rotation of the wheel. The turbine blades are a complex shape, the operating mechanism of the turbine is partly that of an impulse turbine and partly as a reaction turbine. As the gas strikes the turbine blade it gives up a portion of momentum to the blade causing it to move. The gas flow over the blades is such that the pressures on each side are different causing a reaction on the blade and forcing it to move. The blades may be considered to be airfoils or tiny wings, the “lift” produced per blade results in rotational torque.

The combined effect of the stationary turbine nozzle and the rotating turbine wheel is to reduce the pressure, velocity and temperature of the gases flowing through it. Work is extracted by the turbine (to drive the compressor) and so the energy in the gas stream is reduced. The turbine assembly may be considered to be similar to that of the compressor but working in reverse.

The axial flow turbine wheel turns inside a very close fitting shroud, the gap between the shroud and the turbine blade tips must be kept as small as is practicable. A small clearance between the blades and the shroud ensures no significant amounts of gas bypass the turbine reducing the efficiency of the stage. In small engines gaps measuring as little as 5 thousandths of an inch are possible. The turbine wheel and associated nozzle is manufactured from a high temperature alloy such as Nimonic or other high temperature steels. The turbine must withstand very high temperatures, resist corrosion, high rotational forces and remain within very tight mechanical dimensional tolerances. Over the operating life of the engine the wheel will experience many heat cycles when the engine is started and stopped, these thermal cycles must not have a detrimental effect on the wheel. Eventually over time the wheel may suffer cracking and the dimensions may expand due to creep, periodically as part of an engine overhaul the wheel must be checked and inspected. The blade tips may also become eroded and burnt on high life turbine wheels that will reduce the efficiency.

### **Radial flow turbine**

A radial flow turbine wheel may be described as an impellor type compressor wheel working in reverse. A ring of tangentially arranged static vanes form nozzles through which the hot gasses from the combustion chamber are directed on to the impeller shaped wheel around its circumference. The gases initially flow in the direction of the wheel rotation and impinge on the impellor radial vanes. The gases flow inward and additional curved rotating blades then guide them out along the rotor axis and to the engine exhaust outlet.

A radial flow turbine wheel is almost universally used in small automotive turbo-chargers, it is more efficient than a single stage axial flow wheel. It has the advantage that the running tolerances are more relaxed, as the running clearances around the impellor blades are found to be less critical on this type of wheel.

Many small engines use radial inflow turbine wheels, they are very common in Garrett APUs, the German BMW 6012 uses this type, Saurer GT15 is equipped with this type and they can also be found in some Lucas/Rover engines. The larger KG2 industrial gas turbine is also fitted with a single radial inflow wheel.

Due to the favorable mechanical clearances that can be adopted with radial flow turbine wheels, the configuration allows for a particular mechanical engine layout. The compressor and turbine are mounted back-to-back on a common shaft and separated only by a baffle and a seal around the shaft. The bearings supporting the shaft are both placed outboard of the wheels in an "overhung or cantilever configuration". The advantage of this arrangement is that the bearings are placed well away from the "Hot Section" of the engine. This arrangement reduces the temperature of the bearings and exhibits advantages in terms of service life and heat build up. The turbine wheel is placed furthest from the bearings and so any radial movement will be at a maximum at this point. To allow for a small amount of radial movement the clearances around the turbine wheel are relatively large, for this reason a radial inflow wheel is favored. The gas flow around the wheels is also straight forward as it exits the compressor and enters the turbine around the circumference, keeping the whole configuration as short as possible.

A second advantage of an overhung bearing arrangement is that the hot section components do not carry a bearing system and so may be removed for inspection without the rotor assembly, associated bearings and seals being disturbed.

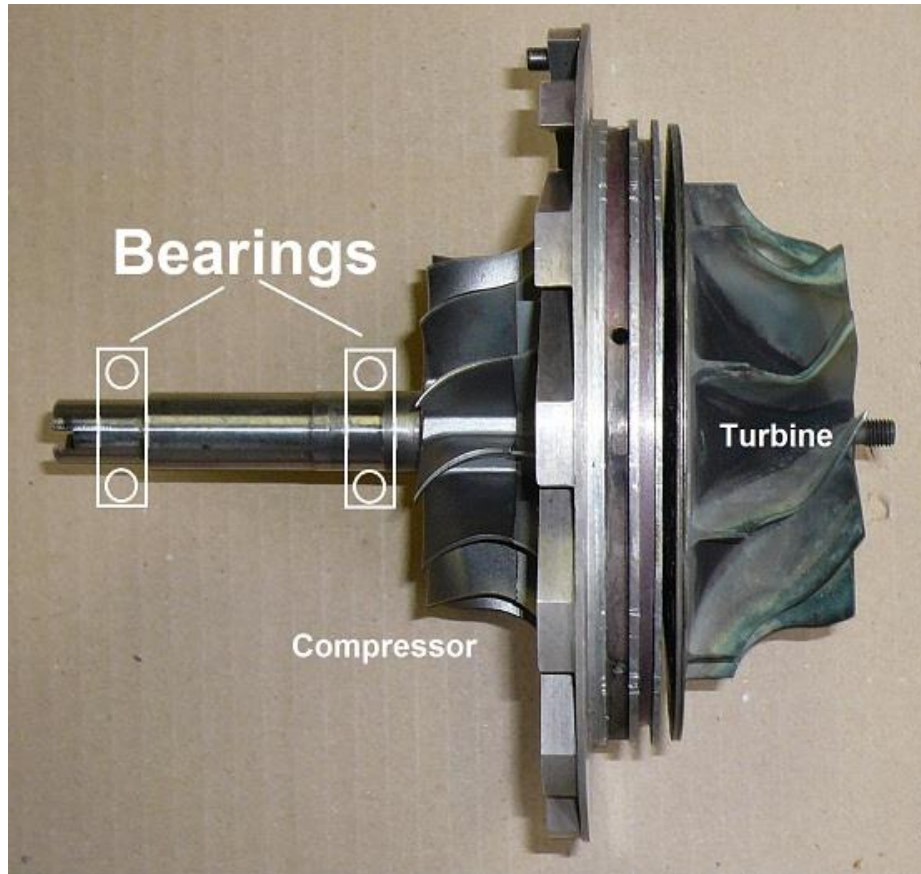

**Over-hung gas turbine rotor bearing support**

Depending on the design of the engine one or more axial flow turbines or one radial inflow turbine may be used to drive the compressor. Most small gas turbines consist of a single shaft layout, i.e. the rotational horsepower developed by the engine is extracted directly from this single shaft. A gearbox is used to reduce the rotational speed so that it may be used to drive a suitable load. Mechanical loads on small gas turbines often consist of electrical generators, pumps or in some cases air compressors. The gearbox is also used to drive various engine accessories such as fuel and oil pumps. When using a single shaft engine, care must be taken to ensure that no significant mechanical load is placed upon the engine until it has successfully started and accelerated to governed speed. Certain types of DC generators are relatively stiff to turn due to high current brush gear, in this case a centrifugal clutch should be used so that the engine does not drive the generator until it has gathered speed, this also relieves the load on the starting system. One example of a single shaft gas turbine directly drives a second compressor, during starting the second compressor is blocked off by a valve and effectively stalled to prevent it absorbing power and loading the engine. Note: Compressors driven by free turbines must never be stalled or an over-speed condition and failure may result.

## Small Gas Turbines by Ian F Bennett

A remarkable system adopted by the company Saurer uses a fluid coupling to engage a load on to the GT15 engine. A fluid coupling connects the gas turbine to a compressor unit, during starting and other operations the fluid coupling is drained of fluid and so does not transmit drive to the compressor. When the compressor is required, fluid is passed into the coupling, it fills up and the drive is transmitted. The fluid used is in fact the kerosene type fuel, the Saurer GT15 gas turbine uses fuel for lubrication, the power transmission and of course for combustion.

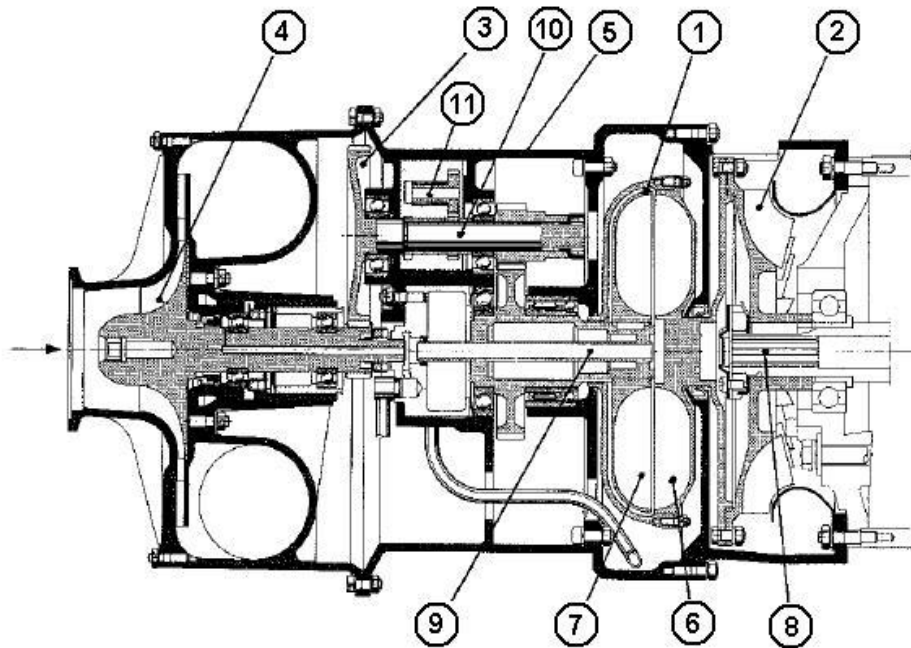

- |                     |                                       |
|---------------------|---------------------------------------|
| 1 Fluid Coupling    | 6 First Torus Half of Fluid Coupling  |
| 2 Cooling Fan       | 7 Second Torus Half of Fluid Coupling |
| 3 Transmission Gear | 8 Driven Shaft from Gas Turbine       |
| 4 Load Compressor   | 9 Output Shaft of Fluid Coupling      |
| 5 Casing            | 10 Layshaft                           |
|                     | 11 Gear Pump                          |

**Hydraulic fluid coupling used to engage drive to a load compressor (Saurer GT15)**



**Gas turbine incorporating fluid drive coupling (Adolph Saurer GT15)**

**Free power turbine (twin-shaft) engine**

A few small gas turbines adopt a twin shaft layout. Here a second turbine wheel mechanically free from the compressor turbine is used to extract power from the engine. Usually, the engine accessories are driven from the compressor turbine to enable this part of the engine to start up. A gas turbine engine that supplies its hot gases to turn a free turbine is sometimes referred to as a "Gas Generator". As the gas generator runs up to speed the hot exhaust acting upon the free turbine gradually accelerates it up to speed, this may take place with a mechanical load already applied.

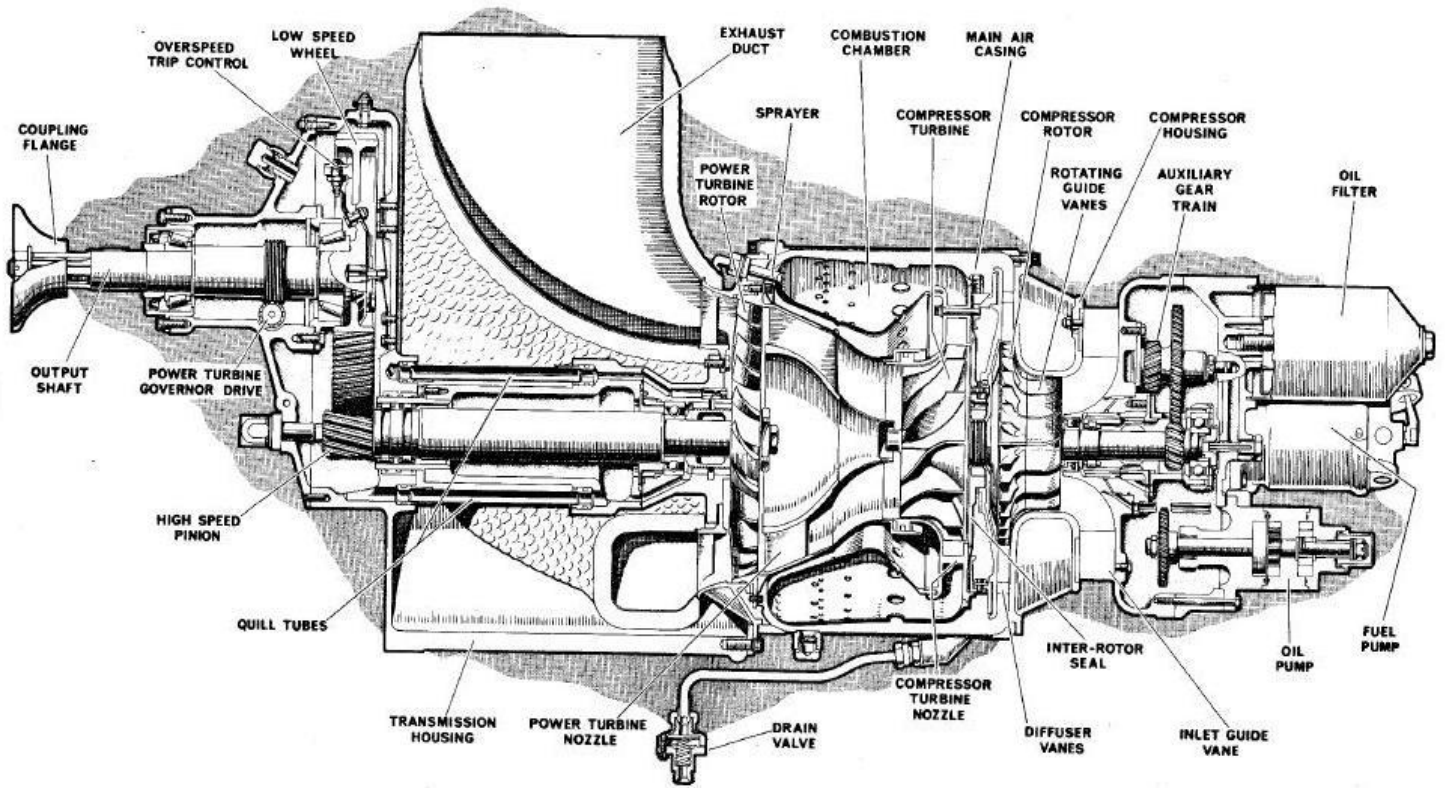

**A small twin-shaft gas turbine engine incorporating a free power turbine stage**

## [Small Gas Turbines by Ian F Bennett](#)



**Twin shaft gas turbine engine incorporating a free power turbine stage  
(Rover AAPP MK10401)**

The main use for this arrangement is in gas turbine starter units (GTSs). A gas turbine starter is basically a small turbo shaft engine which is used to provide direct mechanical effort to spin up a much larger aircraft propulsion engine in a similar way to that of an electric starter motor. The small gas generator section of the GTS is started electrically which in turn spins a free turbine, the free turbine is connected to the propulsion engine through a reduction gearbox. As the main engine runs up to speed the starter can be shut down by means of a centrifugal switch, this function is set to operate when the free turbine reaches a pre-determined speed. A one-way over-running type clutch prevents the started propulsion engine from continuously back-driving the turbine wheel after the start cycle is complete and the GTS has shut down.



**Prototype Rover P6 with 2S150 engine subsequently developed into AAPP Units**

## [Small Gas Turbines by Ian F Bennett](#)

The Plessey "Solent" gas turbine starter unit is an example of a small free turbine engine. This unit was used to rotate the high-pressure spool in a RR Spey engine and was fitted to the now obsolete MD Phantom F4 aircraft. The Solent carried an intermittent rating of some 70 horsepower for the maximum duration of one minute. This rating is mainly due to a one-shot oil lubrication system.



**Small 70HP twin shaft gas turbine (Plessey Solent MK101)**

The one-shot system consisted of a small oil metering mechanism operated by air from the compressor. The Solent, gas generator section spins at 60,000 rpm and the free turbine cut of speed is 50,000 rpm. A twin stage epicyclic reduction gearbox with a ratio of 11:1 is used to provide a low-speed output rotation to drive into the RR Spey accessory gearbox.



[Small Gas Turbines by Ian F Bennett](#)



**The Solent GTS MK101 fitted near the front of the RR Spey Aircraft Engine**

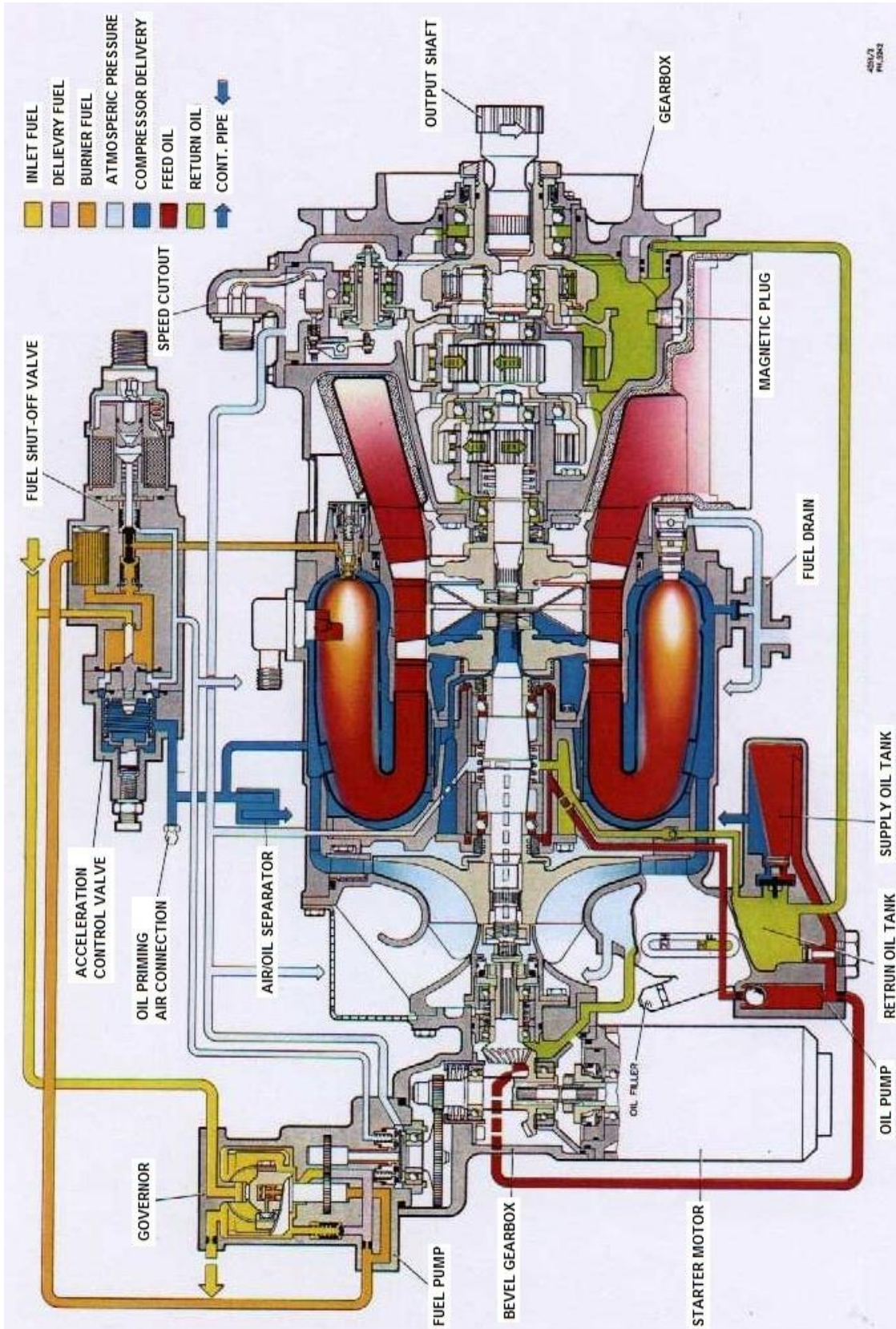

**Plessey Dynamics Solent Gas Turbine Starter MK101**

## [Small Gas Turbines by Ian F Bennett](#)

A unit made by Lucas Aerospace is used to start the RR Pegasus engine in a Harrier VTOL fighter jet. The engine was developed from the Rover twin-shaft car engine. This unit drives through a free turbine and twin epicyclic gearbox to provide an output of some 80 shaft-horsepower. The free turbine is also used to drive a generator without it turning the Pegasus engine over. The free turbine is disconnected from the main engine and a power turbine governor is used to maintain an output speed of 12,000 rpm via an additional train of gears. In this case the gas generator spins at about 55,000 rpm, during the engine starting phase the gas generator speed is increased to 77,000 rpm to provide the extra power needed to start the Pegasus engine. The GTS is able to convert from one mode to another by making use of an elaborate system that applies a brake to the free turbine before coupling it to the stationary Pegasus engine with a dog-type clutch.



**Lucas Aerospace twin-shaft gas turbine engine (CR201)**

## Small Gas Turbines by Ian F Bennett

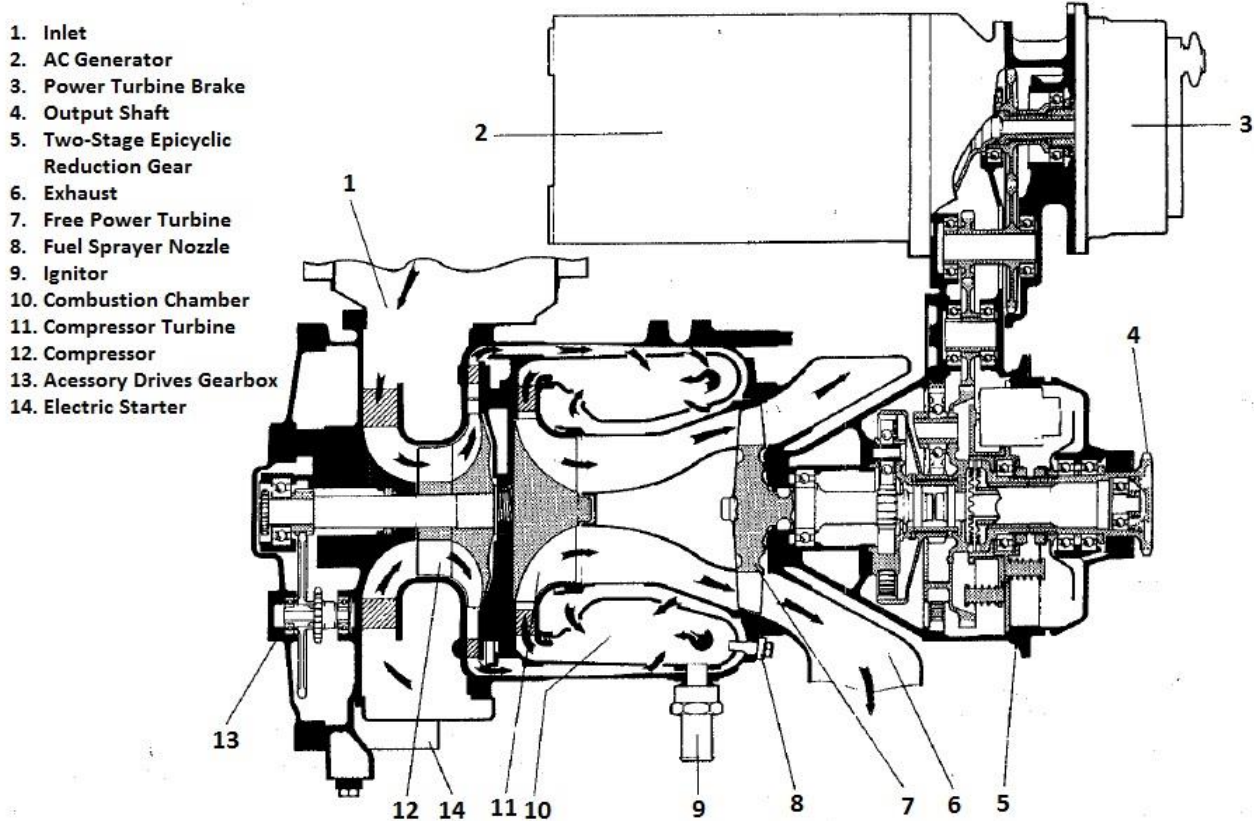

**Lucas twin shaft CR201 APU**

Great care must be taken when operating many free turbine engines, if they are started with no load applied to the free turbine, it will over-speed with potentially catastrophic results. The Solent unit can only be operated in a stand-alone mode only if the free turbine and output gearbox are first removed. The engine then consists of a gas generator which will govern itself at 60,000 rpm. GTSs are normally tested on a special rig, the GTS mechanical output is used to rotate a large flywheel and brake or dynamometer equipped load.

The Lucas engine is fitted with a governor driven from the free turbine, this allows the unit to be operated complete with no external load applied. This mode of operation is first selected by opening a solenoid valve that enables a power turbine governor. During a Pegasus starting operation the GTS bypasses the governor, this must not be allowed to happen if no load is applied to the output i.e. when the GTS is operated stand-alone.

Most larger gas turbines for use as helicopter and turbo-prop engines are also of the twin shaft type, this allows the gas-generator to be started without the main rotor system or propeller placing a load upon it. Common examples such as PW PT6, Turbomeca Arriel, Arrius, GE T58, RR Gnome, Lycoming T53, Lycoming T55 all adopt this layout.

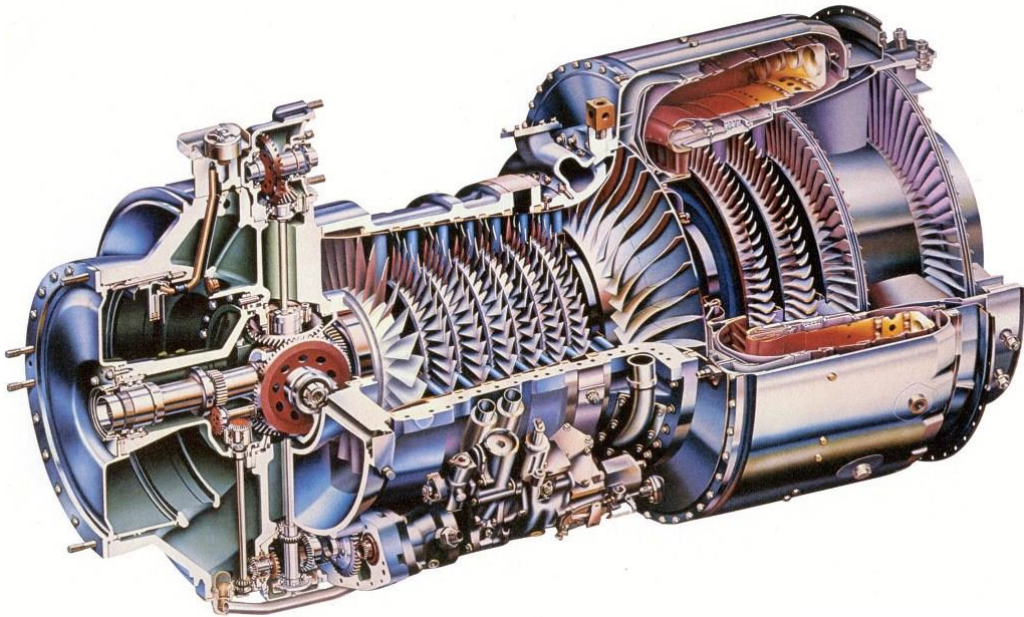

**Lycoming T55 twin-shaft helicopter engine**

There are exceptions to the twin shaft layout in both helicopters and airplanes. The Turbomeca Artouste and Astazou engines drive helicopter rotors systems from just one shaft. These engines are started conventionally whilst disconnected from the rotor systems, a special centrifugal clutch is used to take up load once the engine has past self-sustaining speed and is running at idle. The RR Dart turboprop and the Garrett TPE331 turbo-prop units also operate as single shaft engines. Starting is achieved by “feathering” the driven variable pitch propellers so that they place minimal load upon the engine.

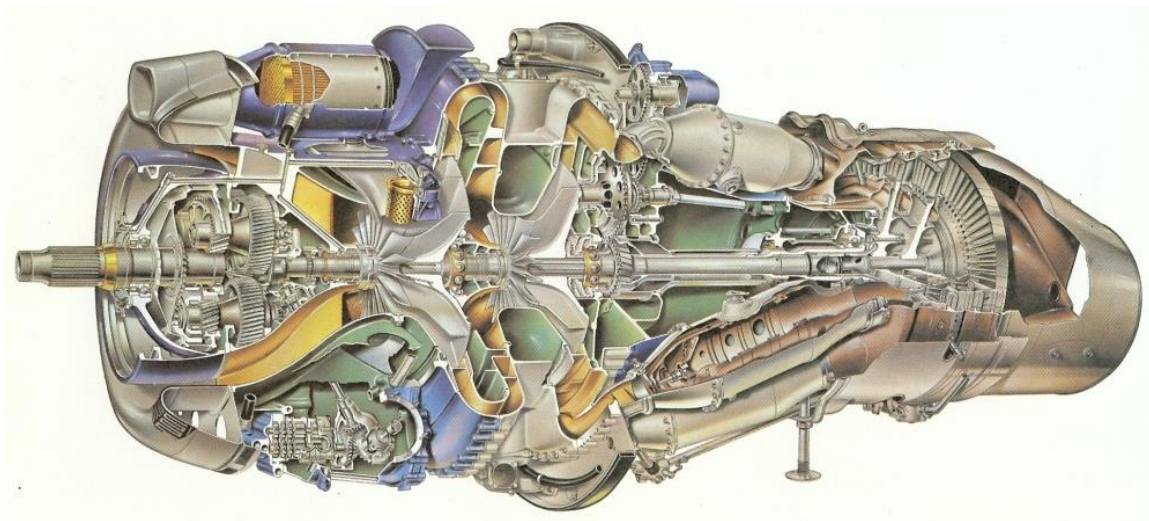

**RR Dart single-shaft turbo-shaft engine**

## [Small Gas Turbines by Ian F Bennett](#)

### **Exhaust systems**

Once the hot gases contained within a gas turbine have passed through the turbine(s) they are discharged to atmosphere. The exhaust emerges through a divergent duct that is sometimes bent around to direct the exhaust in a particular direction. The exhaust is hot and is traveling very quickly, it is potentially dangerous and must be directed away from airframes, equipment and people. In the case of gas turbine starters, power is normally taken off rearward via a gearbox so the exhaust is ducted sharply around a 90 degree bend and out to the one side. Vanes or louvers are sometimes placed in exhaust ducts to help guide the gases, reduce turbulence and eddies which could reduce the efficiency of the engine.

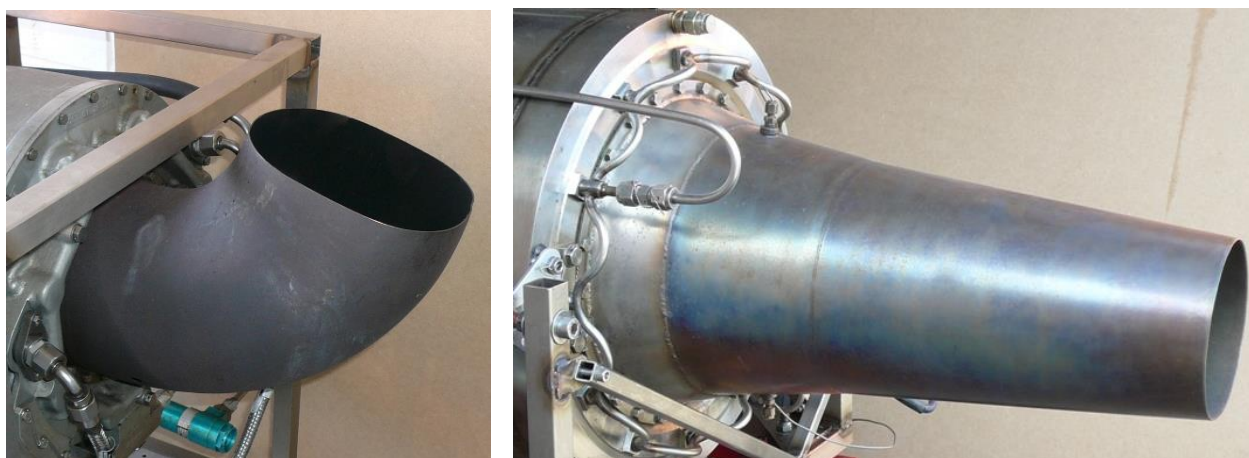

**Gas turbine exhaust ducts Left: APU Right: Turbojet Engine**

An important operating parameter of any gas turbine engine is a measure of the emerging exhaust gas temperature or EGT. The EGT of small gas turbine will vary considerably from type to type and it also depends upon the load and operating conditions placed upon the engine. The EGT is also a very important measure of the health and efficiency of the engine. During start up there is an often an excess of fuel available for combustion and a deficit of air emerging from the compressor, the engine will momentarily run hot until it gathers speed and reaches self-sustaining speed when more air becomes available for cooling. As a load is applied to a running engine, the airflow passing through it remains almost constant but increased fuel is burned in order to maintain the same speed under a load, this results in a higher exhaust temperature. All gas turbine engines have specified limits for maximum starting and running exhaust temperatures, these limits should not be exceeded. A typical starting temperature for a GTS could be as much as 750 degrees C, this is because this type of unit is required to start and run up as quickly as possible. Off load Garrett APU type engines run as cool as low as 280 degrees, off load the Rover 1S60 runs about 400 degrees, a Lucas GTS can run as hot as 500. As a gas turbine starts the exhaust temperature normally rises rapidly after "Light Up", reaches a peak and then settles back to a lower value when idle speed is reached.



**Angled exhaust duct fitted with louver/guides to improve exhaust gas flow**

The section on instrumentation details various ways of measuring and monitoring exhaust gas temperature.

## **Silencers**

The operating principals of exhaust and air intake silencers is essentially the same. Acoustic splitters consisting of absorbing glass fiber packing contained with perforated metal sheet are placed in the intake air path and exhaust outlet. In the case of an exhaust silencer the usual construction material is stainless steel to prevent corrosion and resist the high exhaust temperatures.

Engine housings and enclosures may also contain acoustic lining consisting of perforated sheet encapsulating glass fiber insulation. It is also possible to user acoustic expanded foam and high-density rubber foam materials such as “Insul-sheet” to line the enclosure where the exposure to heat is minimal. High density rubber matting is also available to provide vibration damping and absorption on enclosure panels and covers. A disadvantage with many sound insulation materials is that they provide in most cases unwanted thermal insulation enclosures should be well ventilated. Fans may be needed after engine shut down as stored heat will remain in the enclosure for some time.

Insulation materials are available with a special layered construction of different density and compositions to help augment sound reduction and damping.



## [Small Gas Turbines by Ian F Bennett](#)

The illustrations below show examples of silencer units fitted to small gas turbines rated up to 150BHP. Typical exhaust and intake noise attenuation 10dB.



**Small gas turbine exhaust silencer units (Large unit approx 1.5m high)**



**Acoustic splitters in exhaust unit**



**Cylindrical exhaust silencer unit (L=750mm)**



**Air intake silencer unit featuring acoustic splitters**

## Small Gas Turbines by Ian F Bennett

### **Cooling**

Most types of internal combustion engine require cooling of some form or another, in the case of a piston engine they are normally air- or water-cooled employing fans or radiators. In the case of the gas turbine engine, it may be considered to be "Self cooled". The working medium throughout a gas turbine engine is air and there are large quantities of it. The majority of the air will flow from the compressor into the combustion chamber, this air is partly used for combustion and partly used to cool the combustion gases before they enter the turbine. Air is also used to cool a number of other crucial areas within the engine structure.

In certain designs of engine, the vanes or nozzles which divert the combustion gases onto the turbine are actually hollow. Compressor air passes through the nozzles to cool them and to ensure that they remain within an acceptable temperature range. The turbine nozzle guide vanes are the first to receive gases from the combustion chamber, this is one of the hottest part of the engine. As the gases pass through the turbine nozzles and turbine they reduce in temperature and expand as energy is extracted from them.

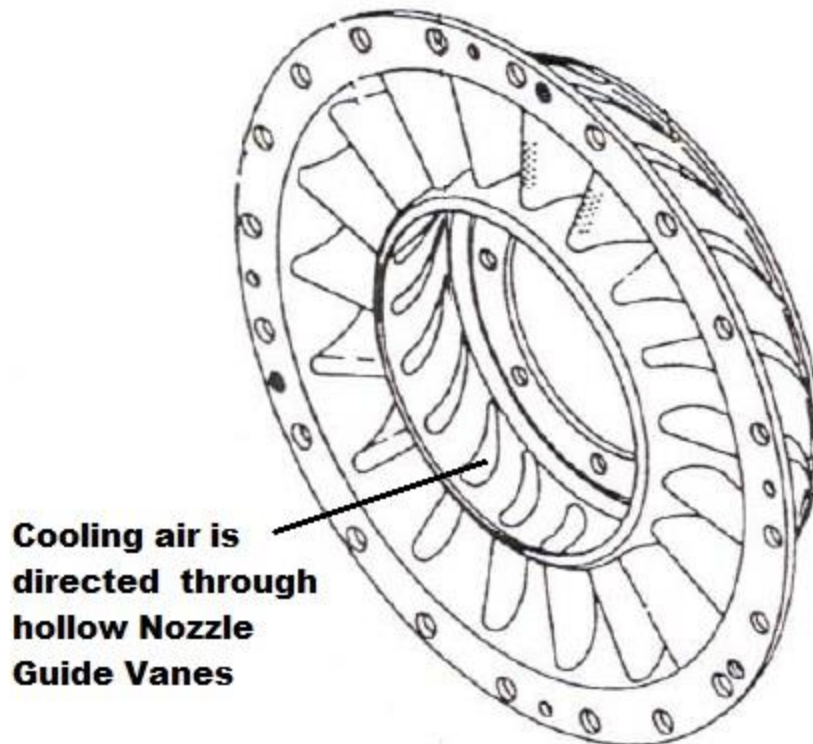

**Turbine Nozzle Ring (Stator) featuring air cooled guide vanes**

Air bled from the compressor is also directed onto the surface of a turbine wheel to reduce its temperature and prevent excessive heat reaching the shaft to which it is attached. Air may also be ducted to the turbine end bearing to keep it cool.

## **Vibration and Balance**

Compressors and turbines rotate at high speed, in the case of a Saurer GT15 APU the maximum speed is some 85,000 rpm. Before assembly, the high-speed rotating components of a gas turbine are accurately dynamically balanced. Dynamic balance refers to the balancing of a wheel radially and along its axis. It is possible to statically balance a wheel so that the centre of mass lies on the rotational axis, however the mass distribution may not be even on each side of the wheel. If the wheel is considered as a whole it is balanced, but if each side of the wheel is considered separately an imbalance can be found. If the wheel is rotated an out of balance force is created which must be corrected.

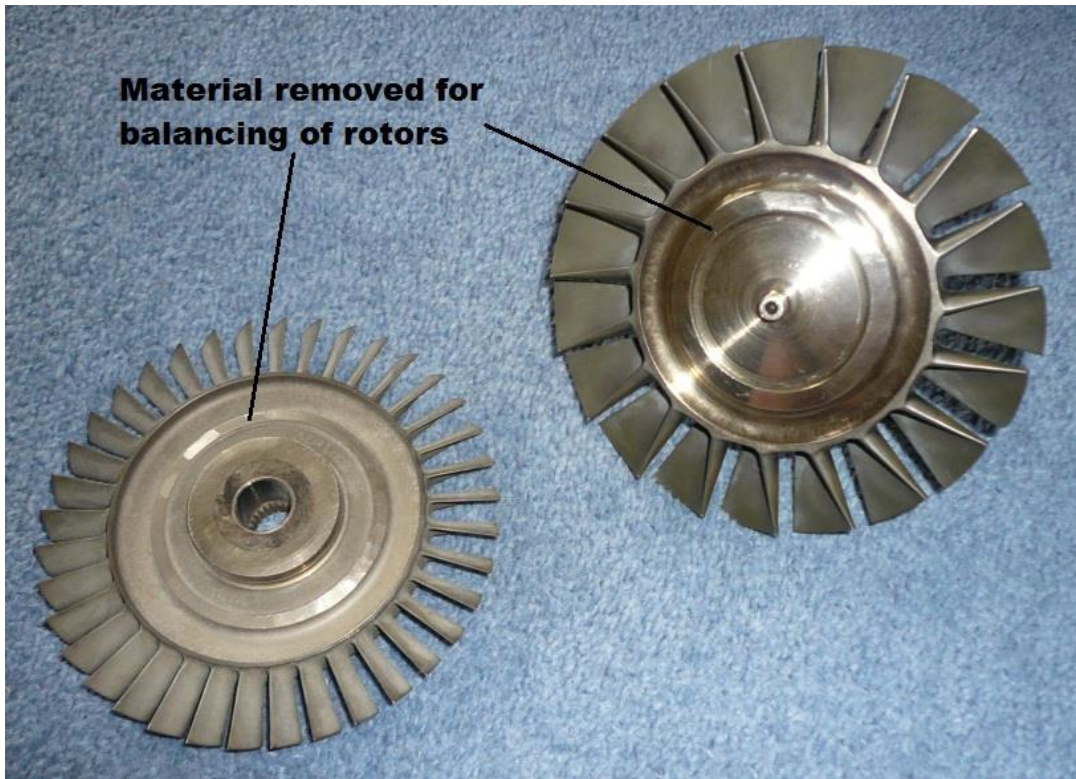

**Balancing of rotors**

Turbine wheels and compressors should be balanced on a special dynamic balancing machine or rig built for the purpose. The machine rotates the wheels at a few hundred rpm and by means of a series of transducers; it detects the resulting vibration generated by any imbalance. The transducer signal is displayed on an oscilloscope or other indicating device. By placing small temporary weights on to the wheel (Often plasticine), the balance may be improved and the vibration signal reduced. Once balanced with the temporary weights, the wheel is machined at a position radially opposite the location of the weights. The machining is carried out on both sides of the wheel and the balancing weights removed; the balance of the corrected wheel is then re-checked on the machine.

## [Small Gas Turbines by Ian F Bennett](#)

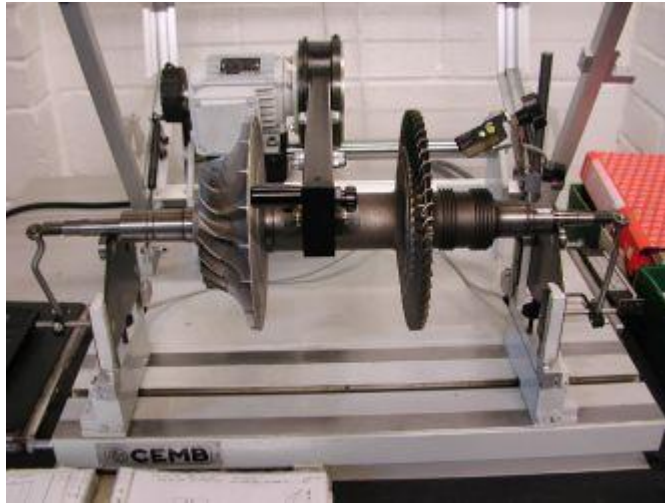

**Dynamic balancing machine**

Turbine wheels and compressors are manufactured with regions of metal which are intended for removal to aid balancing. A circular ridge is provided on each side of an axial turbine disc, portions of which are ground off when the wheel is balanced. A similar ridge is also provided on the rear face of a compressor wheel. Small holes may also be drilled into the central boss near the front of the wheel and small chunks can also be removed from the wheel circumference. When inspecting a wheel; missing portions should be checked carefully to ensure that they are identified as balancing points and not the result of damage.

Small gas turbine engines operate at such high speeds that the rotation of the main shaft gives rise to a characteristic whine. As the engine spools up to speed, a distinctive whistle is produced by the action of the compressor, at governed speed this is relatively high at for instance a frequency of 10 KHz, a lower whine or audible tone may also be heard which is proportional to the rotation of the shaft. An engine turning at 60,000 rpm revolves 1000 times per second; this gives rise to an audio tone of 1 KHz. A running engine exhibiting good balance will produce a note quieter than that of an inferior unit. Poor balance may manifest itself as harmonic sounds and resonances as the engine spools up and down. Bearing assemblies also play a part on the effects of balance; the bearings support the rotational shaft and so aid in dampening vibration and resonances.

High-speed rotating shafts exhibit what is known as “critical” speeds. At certain speeds interaction occurs between the bearings supporting the shaft, the shaft stiffness and the rotating mass of the wheels. This interaction results in vibration and resonances, as the rotor turns it does not spin true but instead whirls (revolves eccentrically) and distorts slightly, many engines accelerate through these speeds and are carefully designed so that they do not suffer any detrimental effects. A gas turbine should not be operated continuously at a shaft critical speed as wear and damage to it will result.

If it is suspected an engine is out of balance due to rough running or vibration it should over-hauled, and the balance of the rotor checked.

## Small Gas Turbines by Ian F Bennett

### **Fuel efficiency**

Compared to many other prime mover power plants small gas turbines are not very efficient sources of power. This is one of the reasons why their application is generally restricted to aircraft where they find advantages in terms of size, weight and the fact they burn the same fuel as the propulsion engines. Larger gas turbines rated at many thousands of horsepower offer much improved efficiency.

The main reasons for poor overall fuel efficiency in small gas turbines can be attributed to the following causes-

1. Small gas turbines that operate with only a single stage compressor or lightly loaded two-stage compressor raise the air pressure by a maximum of about four times that of atmospheric pressure. In heat engines the more the air is compressed the more it can expand when heated, also the more energy is released. Engines with higher pressure ratios burn less fuel as more energy is released during the increased expansion. The pressure drops as the gases flow through the turbines and eventually becomes atmospheric as it leaves the exhaust. More turbine stages (Extracting more power) are possible with larger higher pressure ratio engines.

2. When the air is heated by combustion in a gas turbine the expansion is determined by the temperature rise. The higher the inlet temperature to the turbine, the more expansion can take place in the turbine and more power is released. If the gases are cooled before entering the turbine, then energy is lost which is not available to develop mechanical power. Larger engines with more sophisticated cooled turbine nozzles will cope with a higher turbine inlet temperature.

As a small gas turbine engine runs, much of the energy resulting from the burning of fuel ends up as waste heat in the exhaust. It is possible to improve the efficiency of the engine by re-cycling some of this waste heat. A heat exchanger is used to extract heat from the exhaust and use it to raise the temperature of the air entering the combustion chamber. Less fuel is required to be burnt in the combustion chamber for the same turbine inlet temperature and so the engine burns less fuel for a given power output.

Heat exchangers that are fitted to small surplus gas turbines are rare, they are often complicated and bulky. The difficulty in successfully producing a heat exchanger was one of the reasons for the ultimate failure of several automotive gas turbine projects. Heat exchangers may also have large thermal inertia (i.e. they store as well as transfer heat) and so will limit the engine's response to load changes.

[Small Gas Turbines by Ian F Bennett](#)

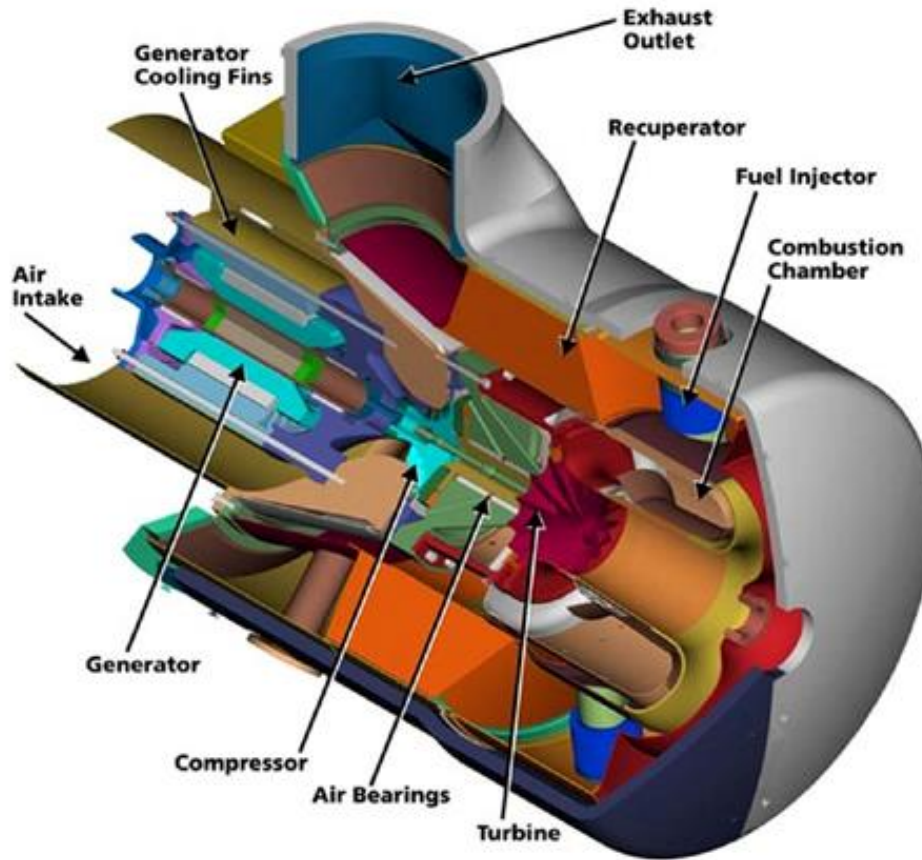

**Small gas turbine fitted with heat exchanger/recuperator (Capstone C60)**



**Small gas turbine architectures**

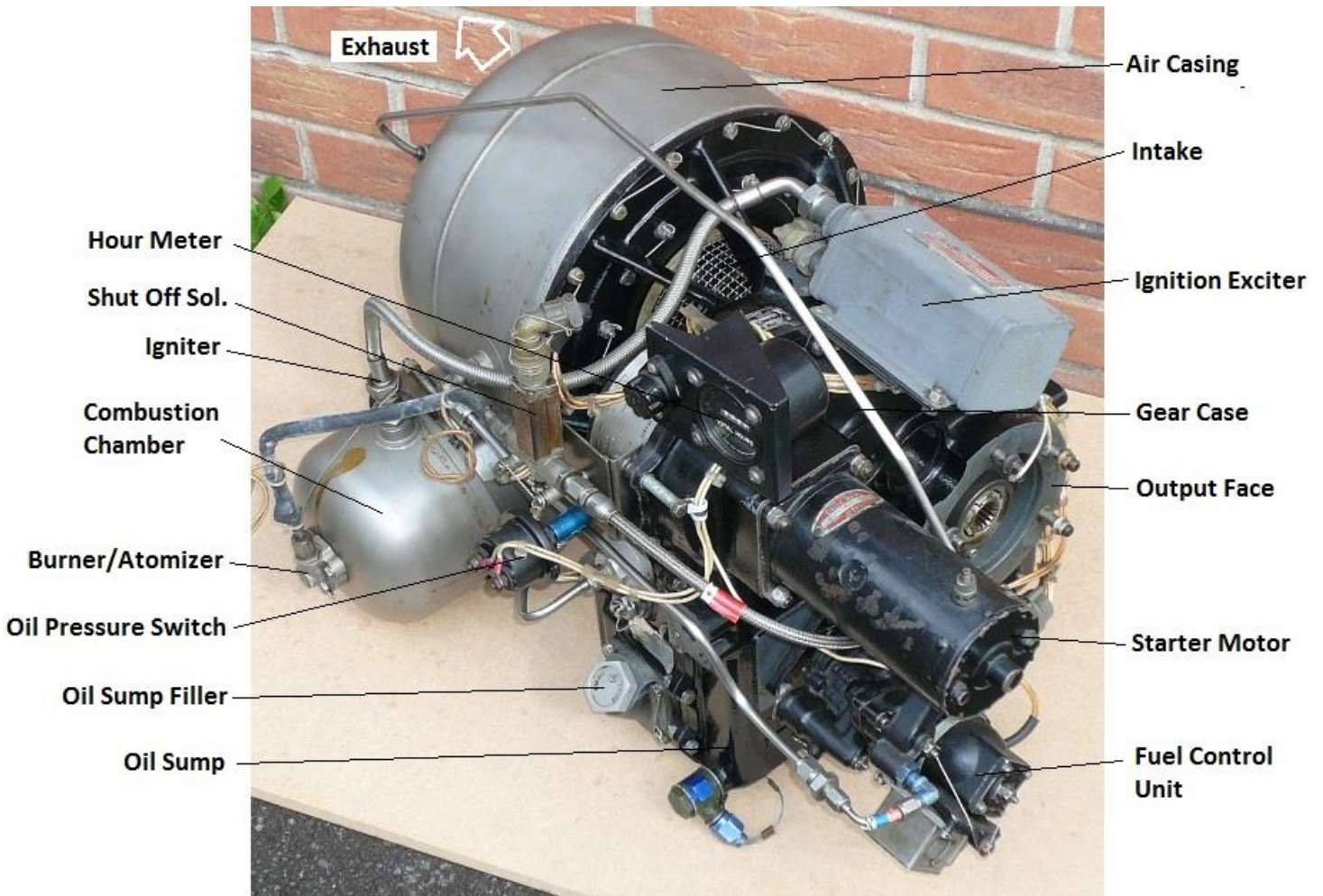

**Typical small gas turbine engine (Garrett GTP30-67)**

A typical small gas turbine engine rated at 40HP (25Kw) is shown above, here a complete running unit is formed by mounting all the systems and accessories on to a reduction and accessory gearbox housing. A hydro-mechanical fuel control system is used here, and a wet sump system is employed for lubrication.

Layouts and architectures in small gas turbine engines vary considerably from model to model.

## [Small Gas Turbines by Ian F Bennett](#)

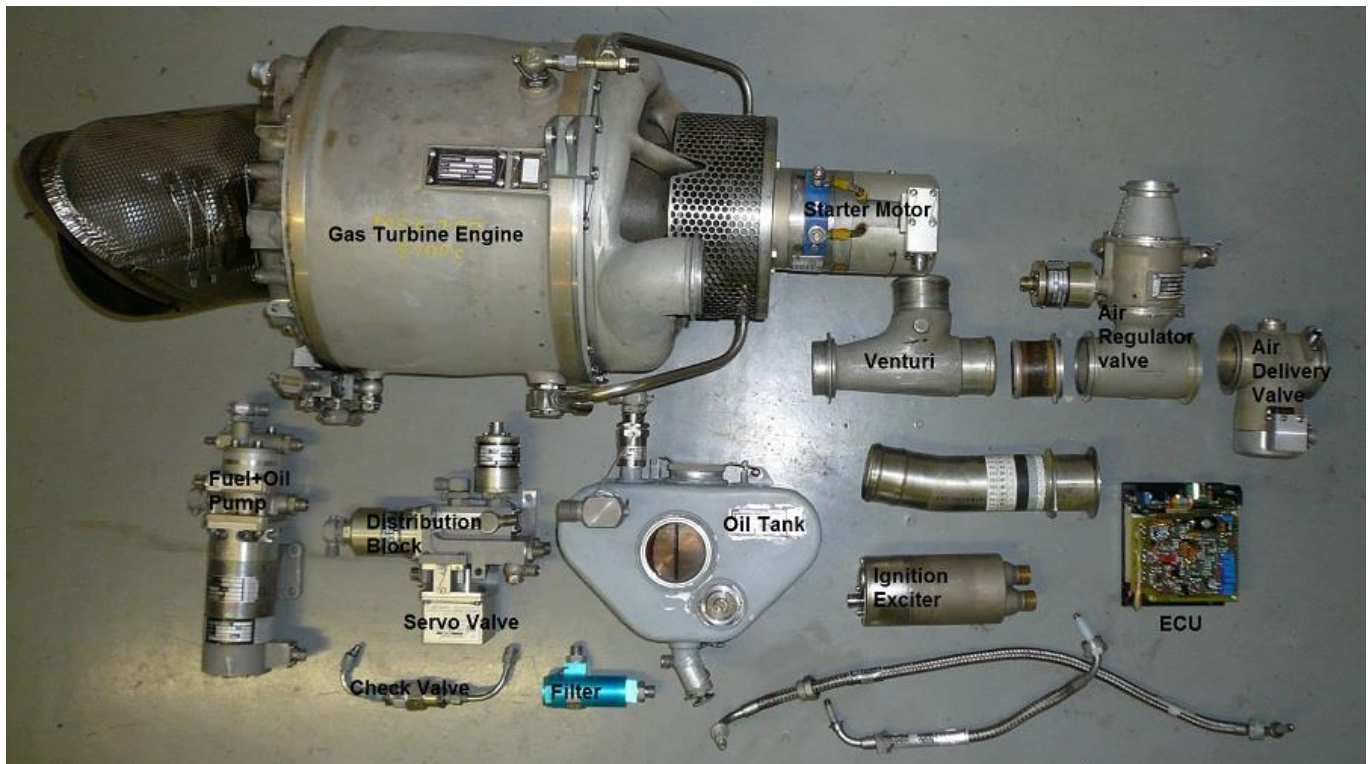

**Disassembled small gas turbine engine employing externally mounted accessories.  
(Microturbo)**

The accessories of this small gas turbine producing up to 50HP equivalent of air delivery are externally mounted and not driven by the engine but instead by an electric motor. All the units shown are required to operate the engine in a self-sufficient manner. The fuel system is controlled by an electronic control unit (ECU) and special metering valve.

[Small Gas Turbines by Ian F Bennett](#)



**Complete assembled 50HP gas turbine engine**

### Micro-turbine gas turbine engines

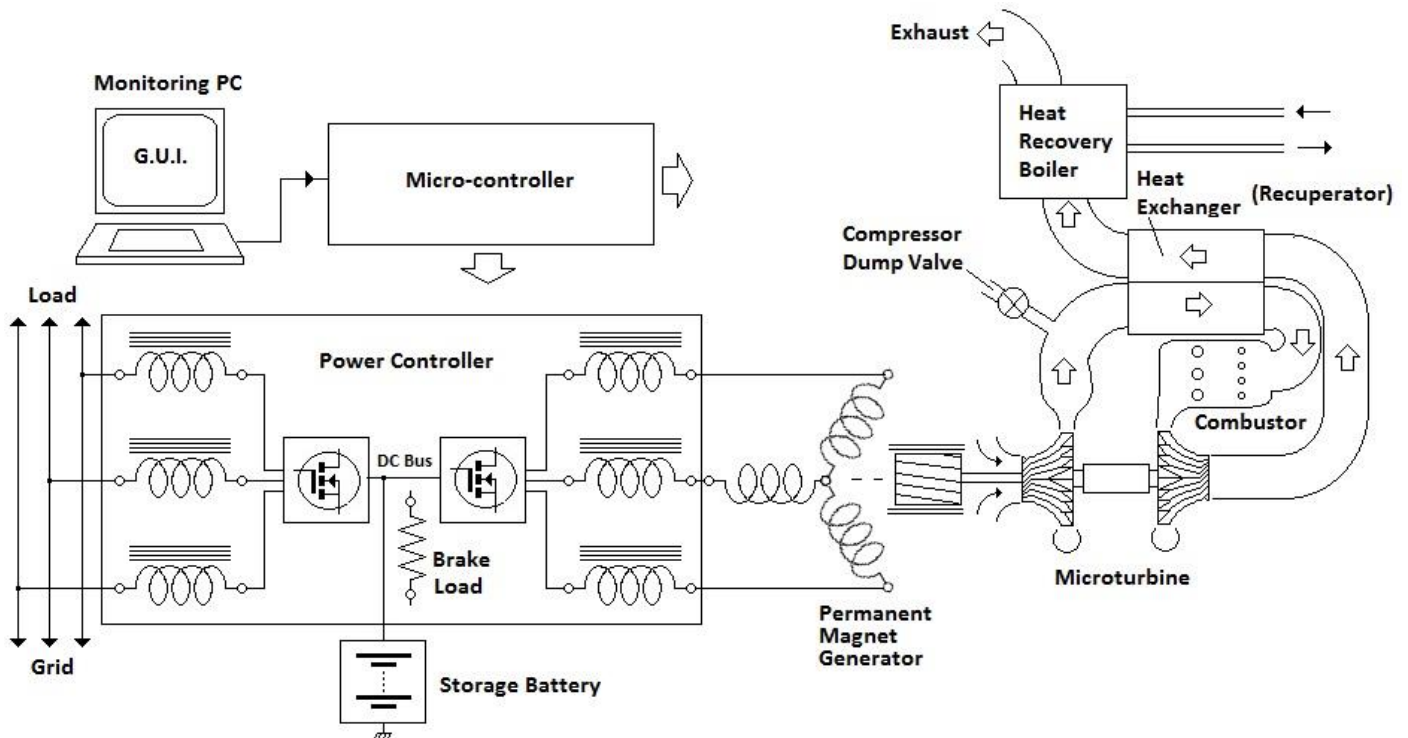

### Simplified schematic of a typical micro-turbine gas turbine engine

The above diagram illustrates a typical micro-turbine gas turbine installation. Micro-turbines occupy a gas turbine engine class of their own, they are not derived from aero engines as they are generally small in comparison and constructed as stationary engines. Micro-turbines compared to established large scale static power generation are very small in size hence the name micro gas turbine. Micro-turbines are manufactured in range of sizes from 30 to 200kw.

A micro turbine rotor consists of a small centrifugal compressor that is driven by a radial inflow turbine wheel. The construction is similar to many medium size turbo-charger components. The rotor assembly is directly connected to a high-speed alternator often constructed as a permanent magnet generator. In some designs the air intake suction air is utilized as cooling air for the generator as the generator is mounted in the intake area. A combustion system is placed between the compressor and turbine and may be fired by liquid or gaseous fuel. The combustor itself may take the form of a reverse flow type with one or more burner nozzles.

## [Small Gas Turbines by Ian F Bennett](#)

The alternator output current flow is of a format that is unsuitable for direct connection to a load so a sophisticated power conditioning unit is employed to convert the generated current into a useful format typically 380V 60Hz 3 phase. The converted output is suitable for connection to the grid system to supplement or augment a mains power if the grid supply fails.



**Combined micro-turbine generator unit and air intake (Capstone C30)**



**Micro-turbine control and power conditioning unit (Capstone DPC)**

## [Small Gas Turbines by Ian F Bennett](#)

Micro-turbines are often fitted with an exhaust gas heat exchanger or recuperator unit. This device extracts heat from the turbine exhaust and recycles it back into the combustion system. The recovered heat energy supplements the heat generated by the burning of fuel and so the overall fuel burn is reduced improving fuel consumption for a given power output.



**Heat exchanger exhaust outlet showing internal matrix (Capstone C30)**

There are different types of heat exchanger design, the most common is formed by a radiator style matrix of passages through which the compressor air flows, it is arranged that the exhaust gas flows through the passages in the matrix and imparts much of its heat to them. Other adjacent passages inside the matrix pick up the heat and raise the temperature of the air supplied by the compressor. The matrix construction is not unlike an automotive style intercooler matrix. The matrix must be constructed of heat resistant steels or stainless steel so that it may cope with the high exhaust temperatures resulting from high loads placed upon the turbine when working at max output. The metallic heat exchanger has a given thermal heat capacity that results in thermal inertia when transients are experienced thus slowing the overall response time (Acceleration and deceleration) of

## [Small Gas Turbines by Ian F Bennett](#)

the turbine unit. Unlike a usual APU style generator running at constant speed and variable exhaust gas temperature, the microturbine aims to run at constant or near constant turbine inlet temperature so that the thermal gradients across the system components change as little as possible during load changes. To do this the microturbine runs at variable speed instead and the resulting variable frequency power output is corrected by the electronics.

Many micro-turbine installations may also feature a waste heat recovery system that is fitted to the system exhaust. This type of installation may be referred to as a combined heat and power (CHP) system. Usually, the exhaust heat is used to heat water as part of a building heating and ventilation system (HVAC). The exhaust gas emerging from the recuperator is simply passed through a second heat exchanger where water is normally heated. Other systems also exist where it is possible to heat other fluids as part of an absorption refrigeration system for instance.

Heat exchangers in small gas turbine systems pose several problems particularly in terms of response times when changes in electrical load are experienced. It is the function of the control system to ensure that a stable output power supply is maintained and that the gas turbine and recuperator assembly are not subject to unnecessary thermal transients. To deal with this problem there are a number of potential solutions-

1. A storage battery system may be used to “buffer” the flow of energy to and from the gas turbine. The heat exchanger may have a large thermal inertia and so the engine will be slow to accelerate and decelerate as load demand changes (As it absorbs and releases heat). The battery via an inverter may be used to temporarily take up the electrical load and the engine speed and load “ramped” up and down to “catch up” with the demand and stabilize with it.

The storage battery system takes a form similar to that of an uninterruptable power supply unit (UPS). When the turbine output cannot meet the power demand then the battery bank takes up the task maintaining continuity of supply like a UPS. The battery is also used for starting and cool-down cycles.

At shut-down a Capstone micro turbine engine actually runs on the stored energy contained in the thermal capacity of the recuperator thermal mass. The control system manages the flow of energy from the generator, as the recuperator cools the generator becomes a motor and maintains a constant turbine speed (and hence cooling air flow) until the exhaust temperature of the unit has reached an acceptable figure for shut down. Careful thermal management of the recuperator is essential to maintain a long service life and reduce thermal shocks to a minimum.



## [Small Gas Turbines by Ian F Bennett](#)

2. A braking resistance inside the power controller system may be used to dissipate excessive electrical energy if the applied load is rapidly reduced. The control system will throttle back the turbine fuel supply (And hence the heat input to the working cycle) and it will decelerate reducing output as the heat in the recuperator is expelled and the system stabilizes at a lower power condition. Unlike a simple cycle gas turbine without a heat exchanger, this type of system cannot instantaneously respond to load changes and so a management system must be used.
  
3. The generator output may be fed into the electrical grid system that acts as a load placed upon the turbine. The grid system may be considered an “infinite bus-bar” system i.e., it has a low impedance, and the excess generated power is allowed to flow into the grid for use elsewhere. During start-up and cool-down, the grid system supplies energy to the turbine. This energy flow process requires precise control by the micro-controller-based system.
  
4. An additional way to rapidly dissipate unwanted energy in a micro-gas turbine is to bleed air from the compressor of the micro-turbine. If the engine is supplying high load and running at maximum rpm and then experiences a large load reduction an air bleed may be employed to divert air and hence gas away from the turbine reducing the spinning force and thus reducing rpm. A dump valve may be fitted to a ducting system that collects air from the compressor diffuser and exhaust it to atmosphere to temporarily stabilize engine rpm.
  
5. In order to operate under light load a micro-turbine may employ a burner switching system that operates the combustion system on a reduced number of burners during low load periods. This will promote stable burning and reduce the risk of flameout when compared to operating multiple burners close to their lower limit of stable operation. This will also improve the likely exhaust emissions as a more precise burn occurs.

Starting of micro-turbine units is achieved by driving the generator unit as a synchronous motor. The electronics used to convert the output current of the alternator are also used to drive the alternator in a sequence necessary for it to rotate the micro-turbine at relatively high speed. For start up, the rotor may first need to be “lifted off the bearing” in air bearing systems typically at 25,000 rpm, the engine is then rotated at light up speed of 35,000 rpm and once lit, accelerated to idle of some 50,000 rpm. A maximum operating speed may be in the order of 96,000 rpm. Once at idle the heat exchanger is allowed to

## [Small Gas Turbines by Ian F Bennett](#)

absorb the exhaust heat. During shut down, the engine may also be rotated by the generator for a period necessary to bring down the heat exchanger temperature to an acceptable minimum before a complete shut-down, this will ensure long life of these components. This process may take up to 10 minutes depending on ambient conditions. Stopping the engine with a hot heat exchanger is likely to reduce the life of this complex component due to thermal shock and expansion/contraction fatigue.

Micro-turbine accessories are generally driven by separate electric motors for services such as liquid fuel or lubricating oil. Many micro-turbines employ air bearings and operate free of liquid lubricants. Micro-turbines are often fired from natural gas or waste process gas, in these cases an external gas compressor unit will be required to raise the gas fuel pressure sufficiently to operate the engine mounted burners.

Control and instrumentation of many stationary micro-turbine engines lends itself to automated and computerized control. Also remote control of multiple units is possible over data links such as modem networks, IP networks and the internet. A Windows graphical user interface (GUI) is used to access all engine controls and parameters. A computer communicates with a local engine mounted microcontroller responsible for interfacing commands and providing indications from the turbine. A manufacturer's proprietary protocol is used to pass data to and from the micro-turbine installation over the data link. A single computer remote from the installation may oversee hundreds of micro-turbine installations. An installation may also have an operator control panel for "Local" control and diagnostics.

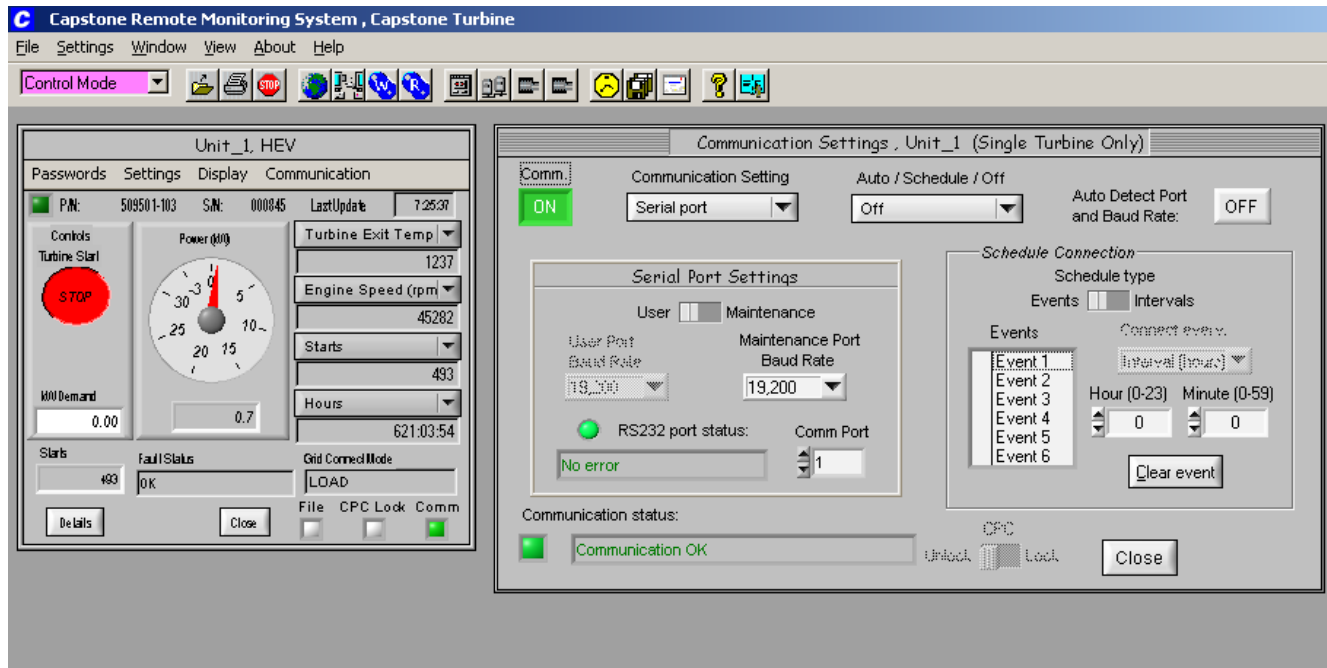

**Typical Windows GUI display controlling a Capstone C30 unit.**



**Capstone operator control panel**

A microturbine generator may typically be controlled via a local user control panel such as the one used by Capstone on the C30 model. All engine parameters and diagnostics are accessible through multiple menu tiers. The system may be password protected to prevent any unwanted tampering with the unit!

## Small Gas Turbines by Ian F Bennett

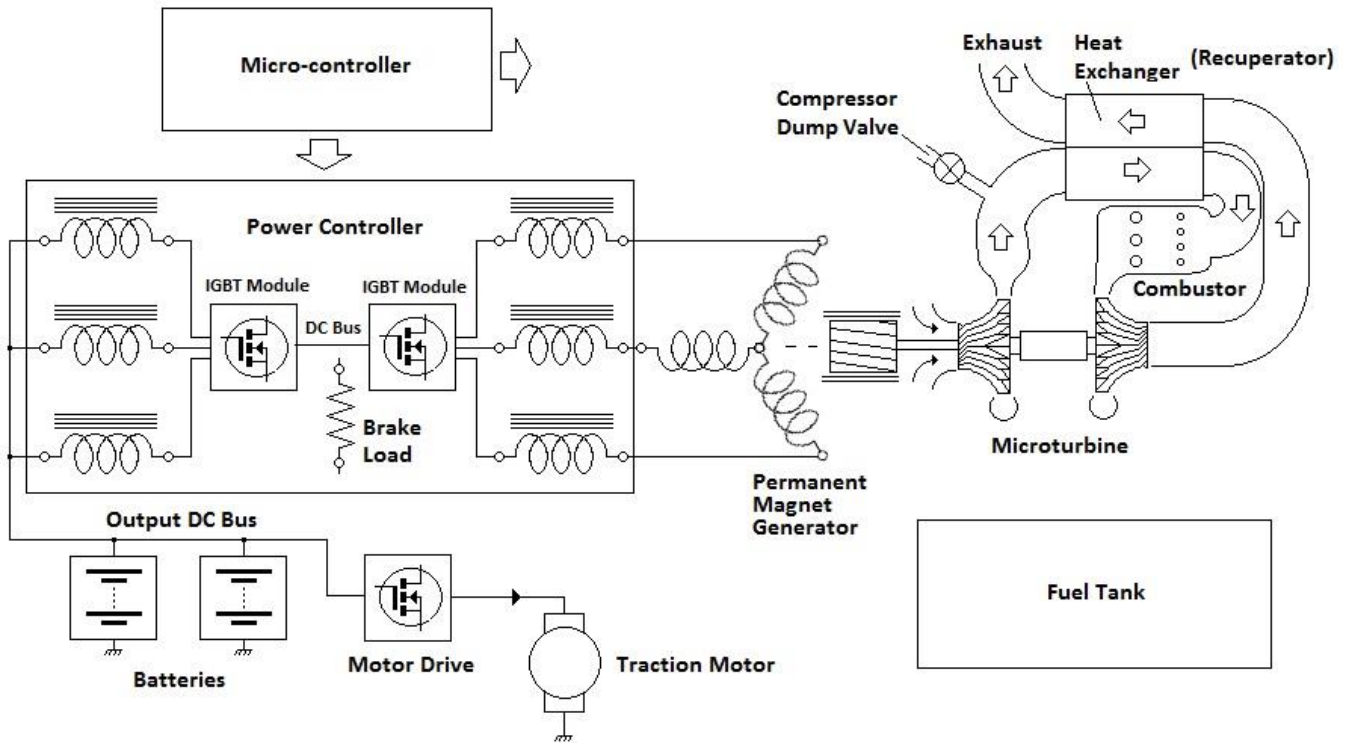

### **Hybrid electric vehicle (range extender) schematic employing micro-turbine generator**

Capstone micro-turbines incorporate a sophisticated GUI. Simultaneous windows displaying basic engine parameters, communication protocol and advanced engine and generator statistics. Devices that form the engine installation are identified with “personality” modules so that the remote system may interrogate the hardware installation and display the modules in use. Differing builds and installations will vary in terms of hardware modules and so the microcontroller and software control adapts to the specific configuration. Engine and power system health is continuously monitored, in the event of a fault the system will alarm and if necessary, shut down the engine. A fault and event history log is kept on file for later analysis. The engine running hours and starts are also recorded so a complete lifetime record is kept of the engine’s use. As well as standby power and grid connect applications micro-turbines can be employed in vehicles.

Electric vehicles may be fitted with a micro-turbine in order to provide a means of extending the useful range of the vehicle. The micro-turbine is used to provide power to maintain the charge of batteries on-board the vehicle and augment greater power when cruising at high speed. The micro-turbine may be operated on a range of liquid fuels including diesel. In the case of diesel, the vehicle may emit lower emissions due to the cleaner burning of the gas turbine compared to a diesel engine itself. Vehicles fitted with micro-turbines may be referred to as “Hybrid” vehicles, however a “Hybrid” vehicle generally uses electric motors and a piston engine to both drive the wheels. A vehicle fitted with a micro-turbine power-plant may be considered to have electric only propulsion as it is only electric motors that are physically connected to the wheels. Micro-turbines are unsuitable for use with mechanical couplings to anything other than

## Small Gas Turbines by Ian F Bennett

high speed alternators. An electrically propelled vehicle fitted with batteries and a micro-turbine may be considered to be an electric vehicle with a “Range Extender” fitted.

The current generation of micro-turbine generators are suited to commercial vehicles and buses due to significant weight and bulk (Mainly due to the batteries and recuperator). Vehicles used for public transport and deliveries particularly in big cities where the authorities may impose exhaust emission regulations are able to exploit the advantages of micro-turbine engines namely better exhaust emissions and lower noise pollution when compared to diesel engines.

Faced with the prospect of fitting a micro gas turbine and associated hardware car size represent more of a installation challenge. A complete system using current technology is bulkier than the original piston engine set up. The batteries even if used for “peak” power (e.g. acceleration) represent much weight and current micro-turbine designs are also heavy and the vehicle still needs to carry liquid fuel in significant quantities.



**Remarkable prototype cars powered by a Capstone micro-turbine (CMT380 and LPE S-Max)**

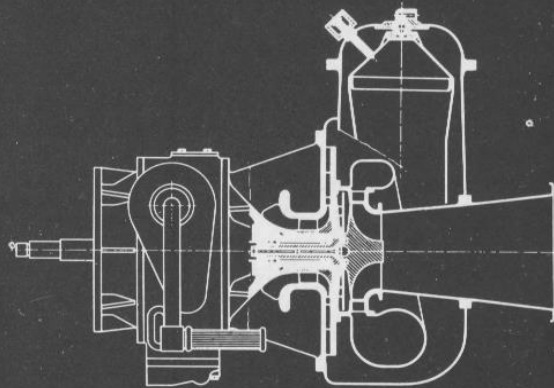
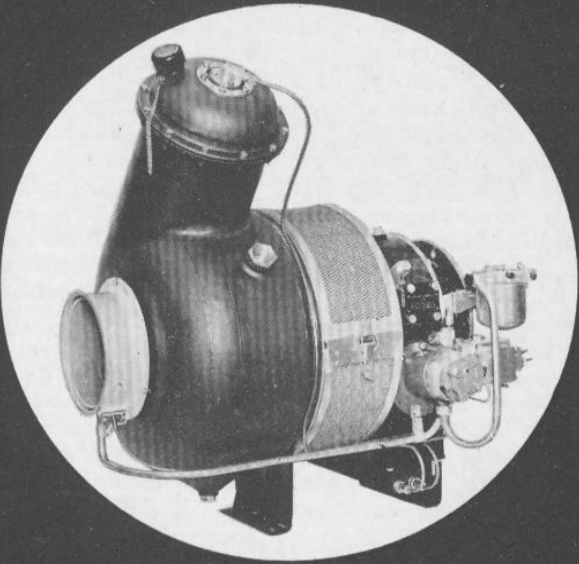

GT 6 E

## Small Gas Turbine T 16

Single-shaft turbine particularly built for industrial application with single-stage radial compressor and single-stage radial turbine impeller. Rugged, wear-resistant design, shockproof operation even with inclinations up to 35°.

Simple to operate, easy to maintain, ready for immediate operation even at temperatures down to minus 40° F (40° C). Weighing 154 lbs (70 kgs) only, this turbine is well suited for all jobs where smallest overall dimensions and lowest possible weight are of utmost importance.

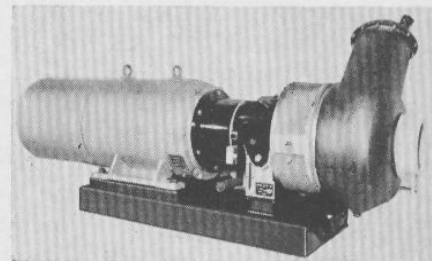
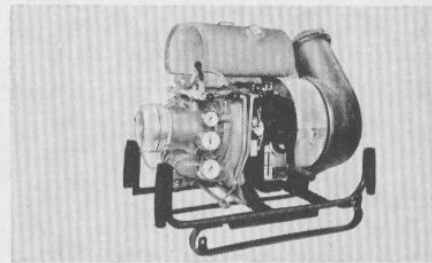

**KLÖCKNER-HUMBOLDT-DEUTZ AG · KÖLN**